

P-6946
S1930
25167

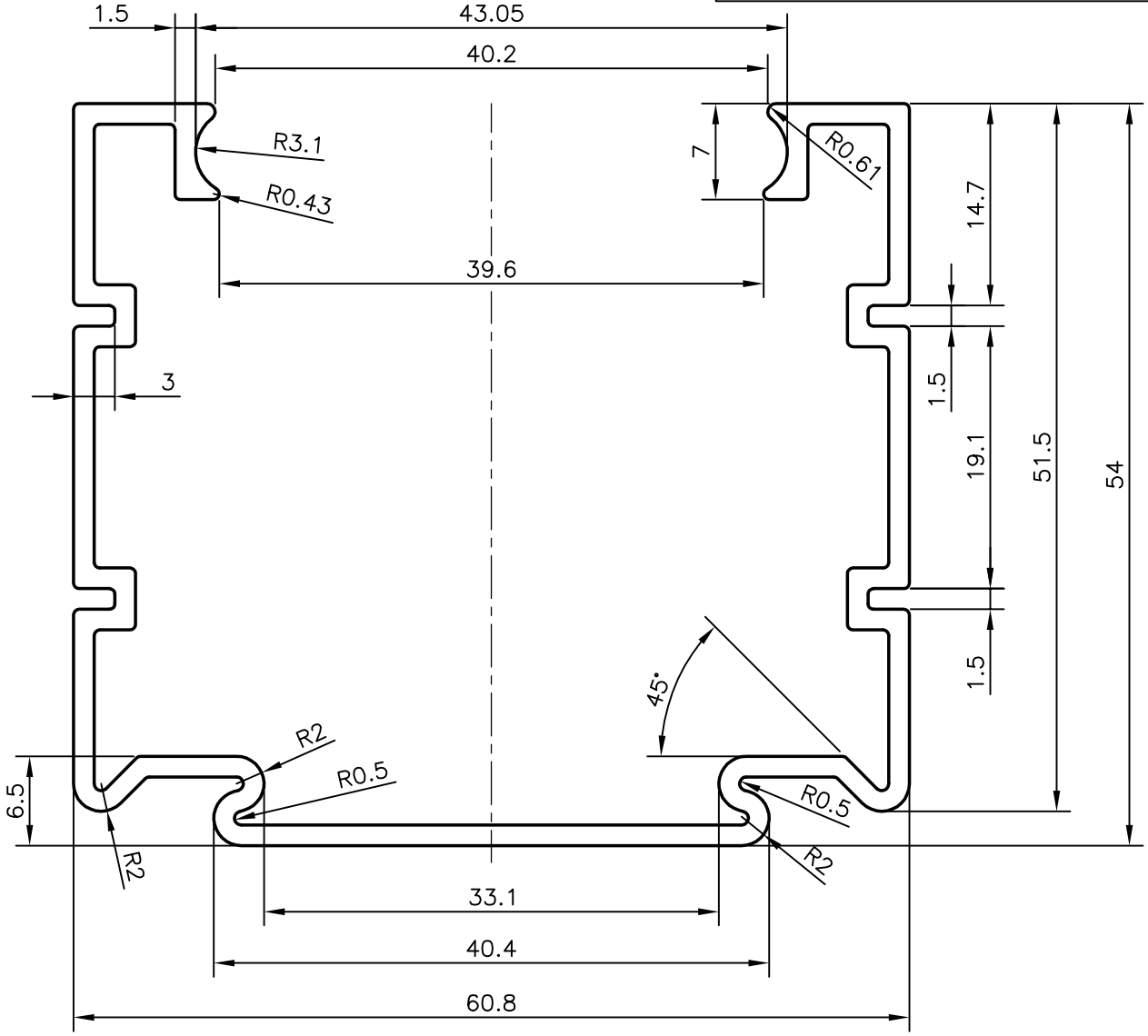

NOTE:- GENERAL WALL THICKNESS = 1.5 mm

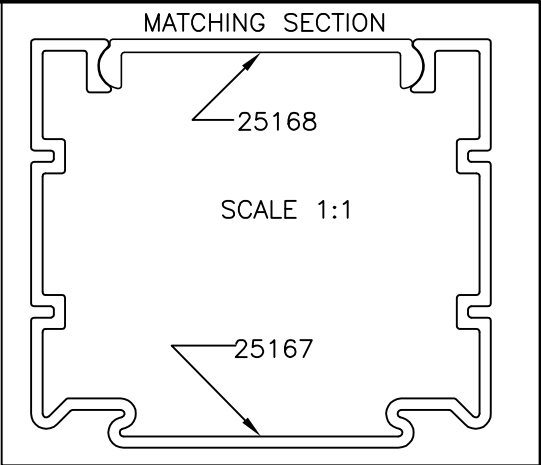

JINDAL ALUMINIUM LTD.
BANGALORE-560073 (INDIA)

	NAME	DATE
DRAWN	PRASANNA.H.	04-01-2007
CHECKED		
APPROVED		

1. ALL DIMENSIONS ARE IN mm.
2. ROUND OFF ALL SHARP CORNERS WITH 0.40 mm.
3. TOLERANCES WILL BE AS PER IS:3965-1981 UNLESS OTHERWISE SPECIFIED

SCALE	2:1
AREA mm ²	348.03
PERIMETER mm.	455.593
WEIGHT kg/m	0.94

PARTY'S NAME	PARAS LIGHTS., BANGALORE
PARTY'S DRAWING No.	AS PER SAMPLE
ALLOY & TEMPER	HE9 WP
DESCRIPTION	MISC. PROFILE - DUCT SECTION

DRAWING No.	SECTION No.
P-6946	-
S1930	S1930
25167	25167