

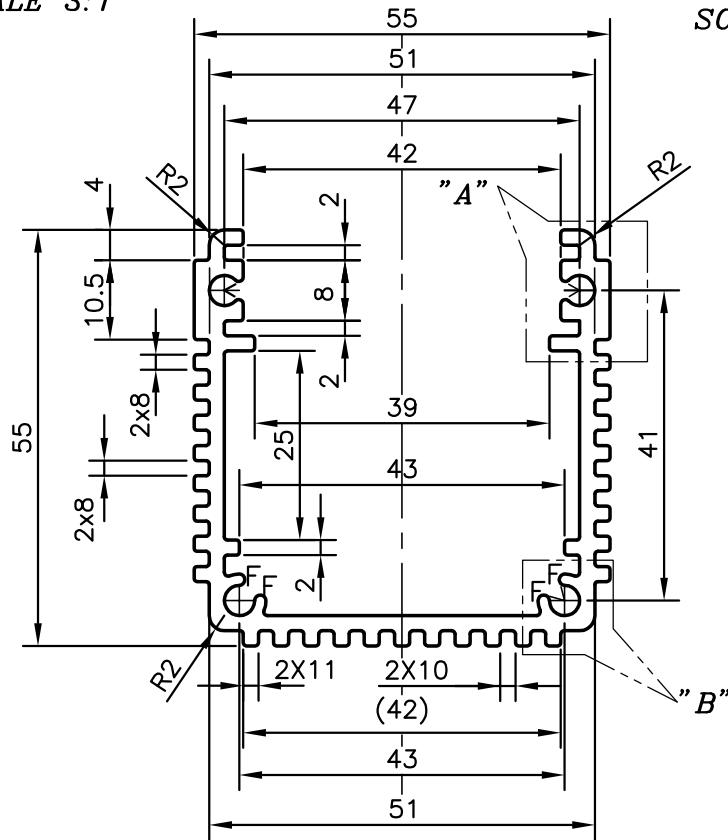

P-9167-1

S2126

25176

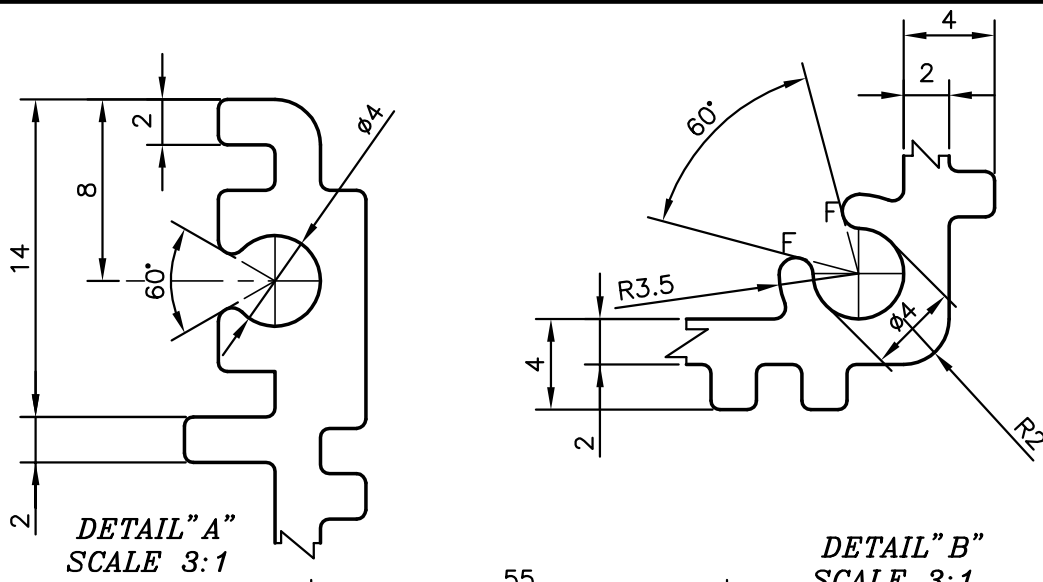

F= FULL RADIUS (4 PLACES)

 SYMBOL OF QUALITY AN ISO 9001 COMPANY	JINDAL ALUMINIUM LTD. BANGALORE-560073 (INDIA)	NAME	DATE
		DRAWN	J.P.KAUSHIK 06-05-2009
		CHECKED	
		APPROVED	
1. ALL DIMENSIONS ARE IN mm. 2. ROUND OFF ALL SHARP CORNERS WITH 0.40 mm. 3. TOLERANCES WILL BE AS PER IS:3965-1981 UNLESS OTHERWISE SPECIFIED		SCALE	1:1
		AREA mm ²	517.436
		PERIMETER mm.	473.767
PARTY'S NAME	THIRD EYE RESEARCH & DEVELOPERS (P) LTD. MUMBAI	WEIGHT kg/m	1.397
PARTY'S DRAWING No.	AS PER DRAWING	DRAWING No.	SECTION No.
ALLOY & TEMPER	HE9 WP	P-9167-1	-
DESCRIPTION	MISC. SECTION	S2126	S2126
		25176	25176