

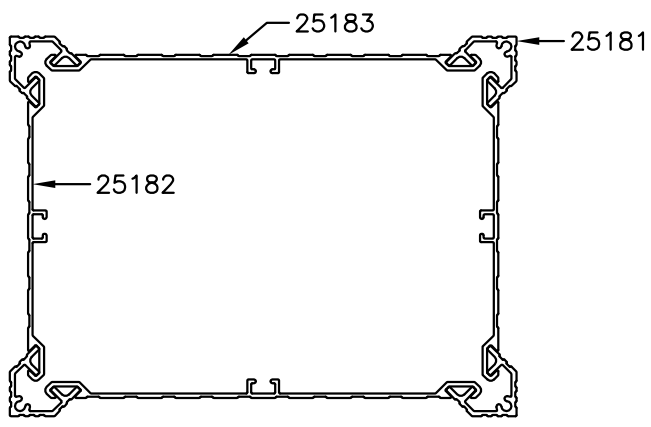

P-9701
S2419
25183

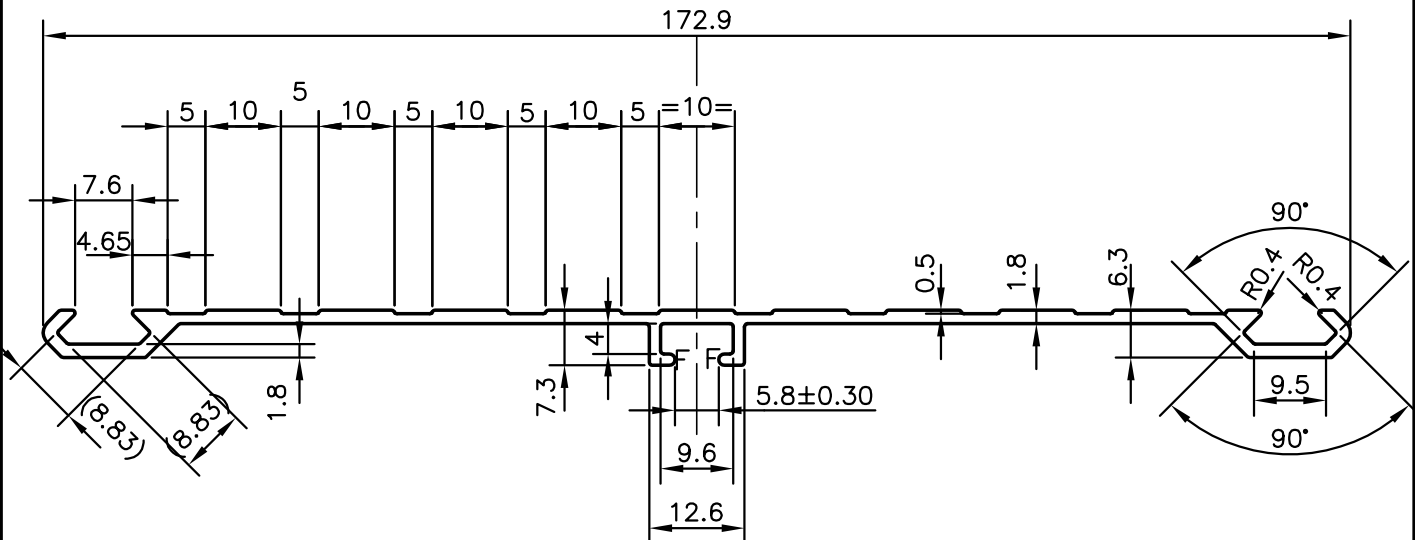
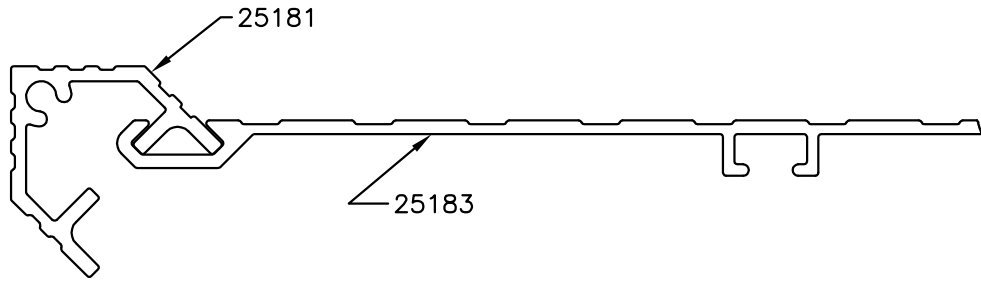

F = FULL RADIUS (2 PLACES)

 SYMBOL OF QUALITY AN ISO 9001 COMPANY	JINDAL ALUMINIUM LTD. BANGALORE-560073 (INDIA)	DRAWN	J.P.KAUSHIK	DATE	24-12-2009
		CHECKED			
1. ALL DIMENSIONS ARE IN mm. 2. ROUND OFF ALL SHARP CORNERS WITH 0.40 mm. 3. TOLERANCES WILL BE AS PER IS:3965-1981, UNLESS OTHERWISE SPECIFIED		SCALE	1:1		
		AREA mm ²	347.515		
PARTY'S NAME TWINKLE LUMINAIRES PVT. LTD., GHAZIABAD		PERIMETER mm.	414.024		
		WEIGHT kg/m	0.938		
PARTY'S DRAWING No. AS PER SAMPLE		DRAWING No.	P-9701		
		SECTION No.	-		
ALLOY & TEMPER HE9 WP			S2419		
			25183		
DESCRIPTION MISC. SECTION					