

P-9431

S2495

25201

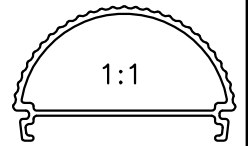

1:1

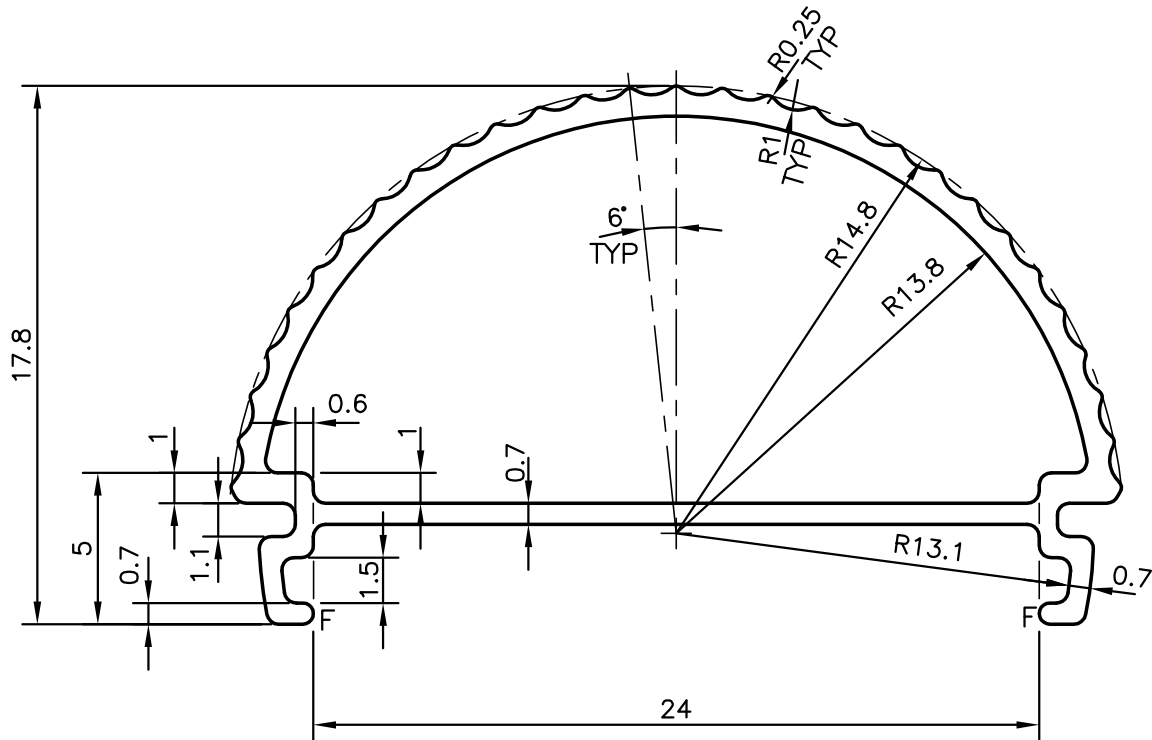

F= FULL RADIUS (2 PLACES)



SYMBOL OF QUALITY
AN ISO 9001 COMPANY

JINDAL ALUMINIUM LTD.
BANGALORE-560073 (INDIA)

	NAME	DATE
DRAWN	J.P.KAUSHIK	08-08-2009
CHECKED		
APPROVED	S.S.GARG	19-03-2010
SCALE		4:1
AREA mm ²		63.948
PERIMETER mm.		96.216
WEIGHT kg/m		0.173
DRAWING No.	SECTION No.	
P-9431	-	
S2495	S2495	
25201	25201	

1. ALL DIMENSIONS ARE IN mm.
2. ROUND OFF ALL SHARP CORNERS WITH 0.40 mm.
3. TOLERANCES WILL BE AS PER IS:6477-1983 UNLESS OTHERWISE SPECIFIED

PARTY'S NAME SRV TELECOM PVT. LTD., BANGALORE

PARTY'S DRAWING No. AS PER DRAWING

ALLOY & TEMPER 6063 T6

DESCRIPTION MISC. SECTION