

P-10429

S2700

25206

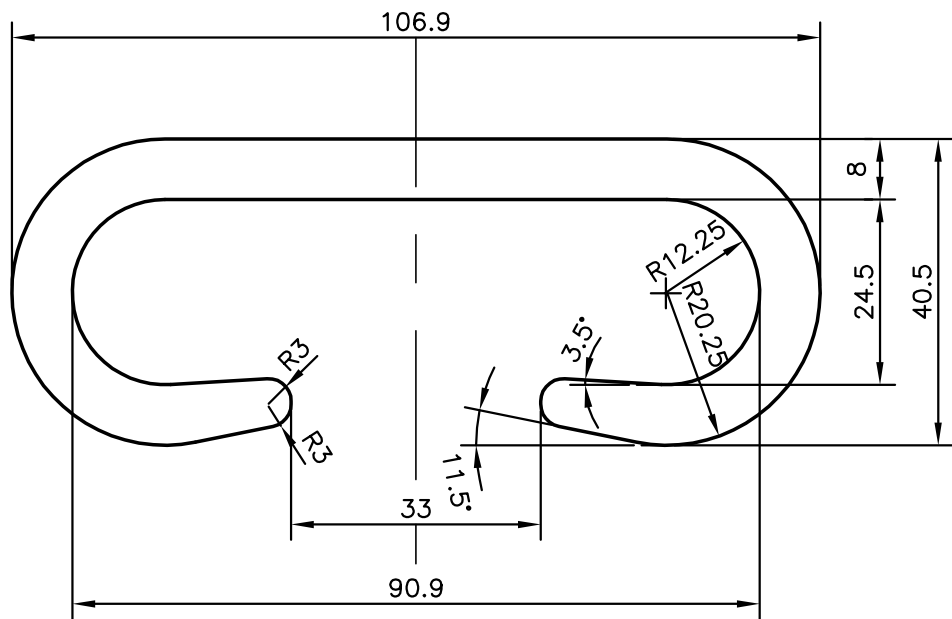

SYMBOL OF QUALITY
AN ISO 9001 COMPANY

JINDAL ALUMINIUM LTD.
BANGALORE-560073 (INDIA)

	NAME	DATE
DRAWN	J.P.KAUSHIK	27-09-2010
CHECKED		
APPROVED		

1. ALL DIMENSIONS ARE IN mm.
2. ROUND OFF ALL SHARP CORNERS WITH 0.40 mm.
3. TOLERANCES WILL BE AS PER IS:3965-1981 UNLESS OTHERWISE SPECIFIED

SCALE	1:1
AREA mm ²	1580.687
PERIMETER mm.	411.92
WEIGHT kg/m	4.268

PARTY'S NAME	SUNLIGHT ELECTRICALS, BANGALORE	DRAWING No.	P-10429	SECTION No.	-
PARTY'S DRAWING No.	SECTION-C NEW	S2700	S2700	25206	25206
ALLOY & TEMPER	6061 T6				
DESCRIPTION	ELECTRICAL SECTION				