

P-11220

S3063

25214

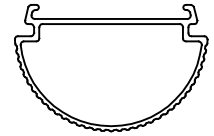

SCALE - 1:1

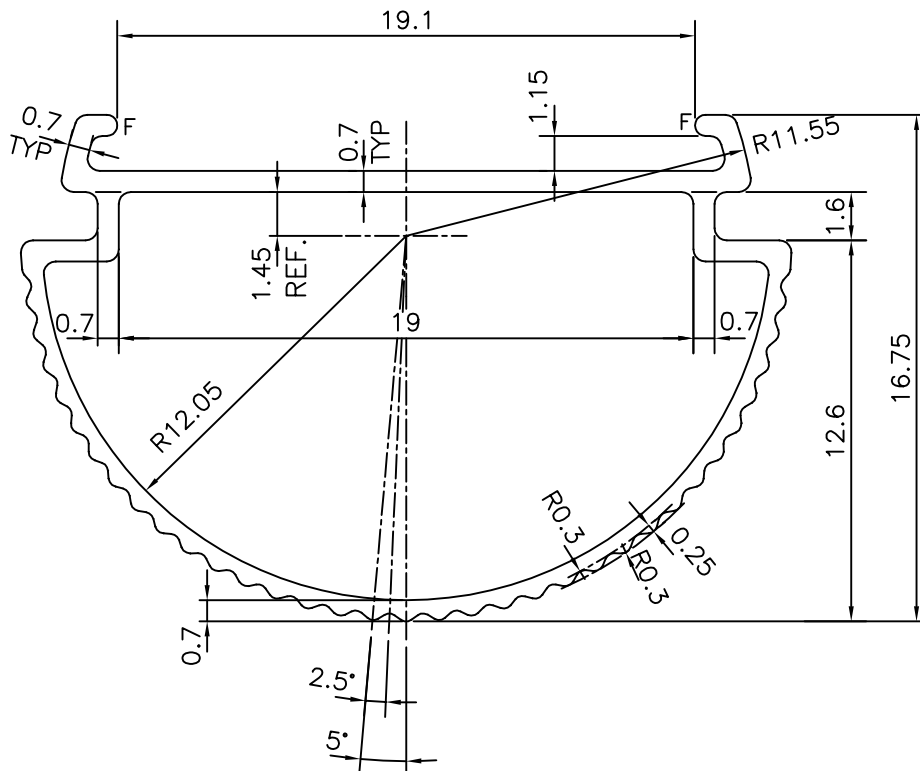

F = FULL RADIUS (2 PLACES)



SYMBOL OF QUALITY
AN ISO 9001 COMPANY

JINDAL ALUMINIUM LTD.
BANGALORE-560073 (INDIA)

	NAME	DATE
DRAWN	J.P.KAUSHIK	28-09-2011
CHECKED		
APPROVED	S.S.GARG	28-09-2011
SCALE		4:1
AREA mm ²		47.824
PERIMETER mm.		86.138
WEIGHT kg/m		0.129
DRAWING No.	SECTION No.	
P-11220	-	
S3063	S3063(ISSUE-2)	
25214	25214	

1. ALL DIMENSIONS ARE IN mm.
2. ROUND OFF ALL SHARP CORNERS WITH 0.40 mm.
3. TOLERANCES WILL BE AS PER,BS:EN-755-9 UNLESS OTHERWISE SPECIFIED

PARTY'S NAME	SPRADECOM ELECTRO CONTROLS, MUMBAI
PARTY'S DRAWING No.	AS PER SAMPLE
ALLOY & TEMPER	HE9 WP
DESCRIPTION	TUBE LIGHT SECTION