

P-12463-1

S3660

25243

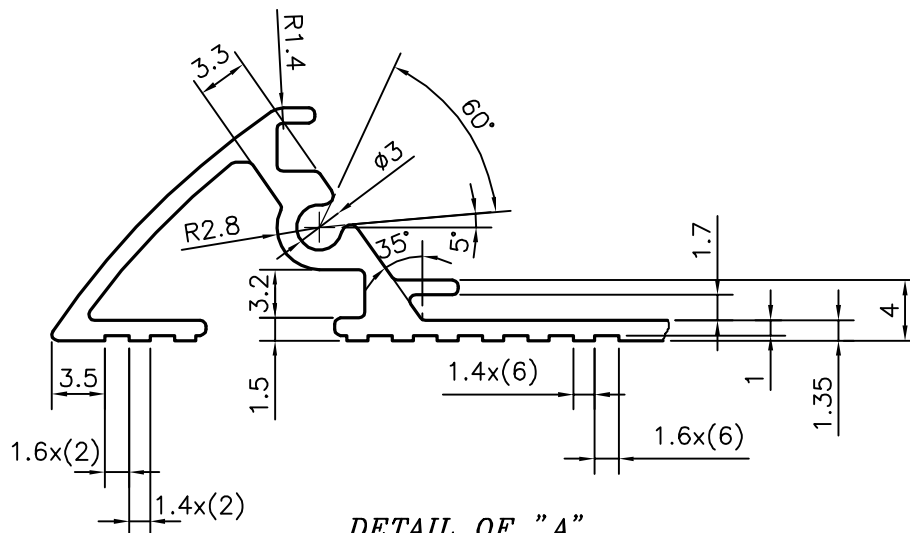

DETAIL OF "A"
SCALE 2:1

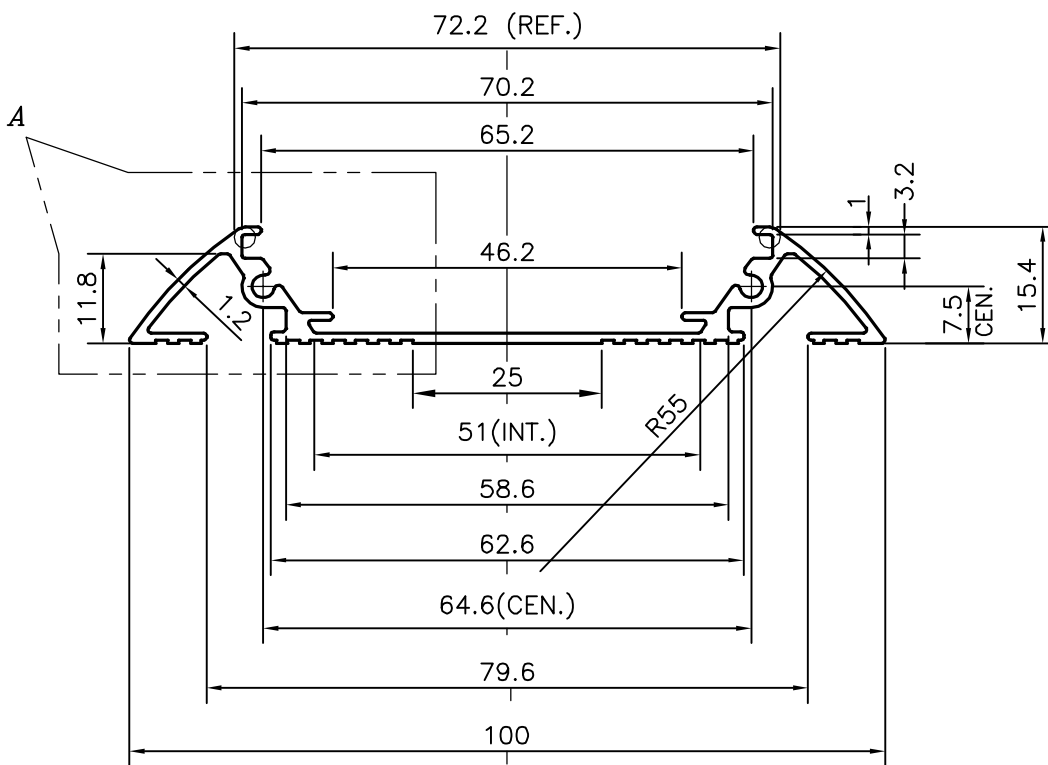

SYMBOL OF QUALITY
AN ISO 9001 COMPANY

JINDAL ALUMINIUM LTD.
BANGALORE-560073 (INDIA)

	NAME	DATE
DRAWN	SRIVATHSA	11-02-2013
CHECKED		
APPROVED	S.S.GARG	13-02-2013
SCALE		1:1
AREA mm ²		233.23
PERIMETER mm.		346.092
WEIGHT kg/m		0.63
DRAWING No.	SECTION No.	
P-12463-1	-	
S3660	S3660	
25243	25243	

1. ALL DIMENSIONS ARE IN mm.
2. ROUND OFF ALL SHARP CORNERS WITH 0.40 mm.
3. TOLERANCES WILL BE AS PER IS:3965-1981, UNLESS OTHERWISE SPECIFIED

PARTY'S NAME FENEX LUMINOUS PVT. LTD., BANGALORE

PARTY'S DRAWING No. AS PER SAMPLE & REQUIREMENT

ALLOY & TEMPER 6063 T6

DESCRIPTION MISC. SECTION