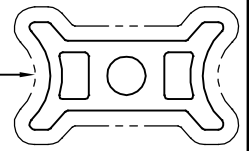

P-12899

S3808

25247

EXPOSED
SURFACE

SCALE 1:1

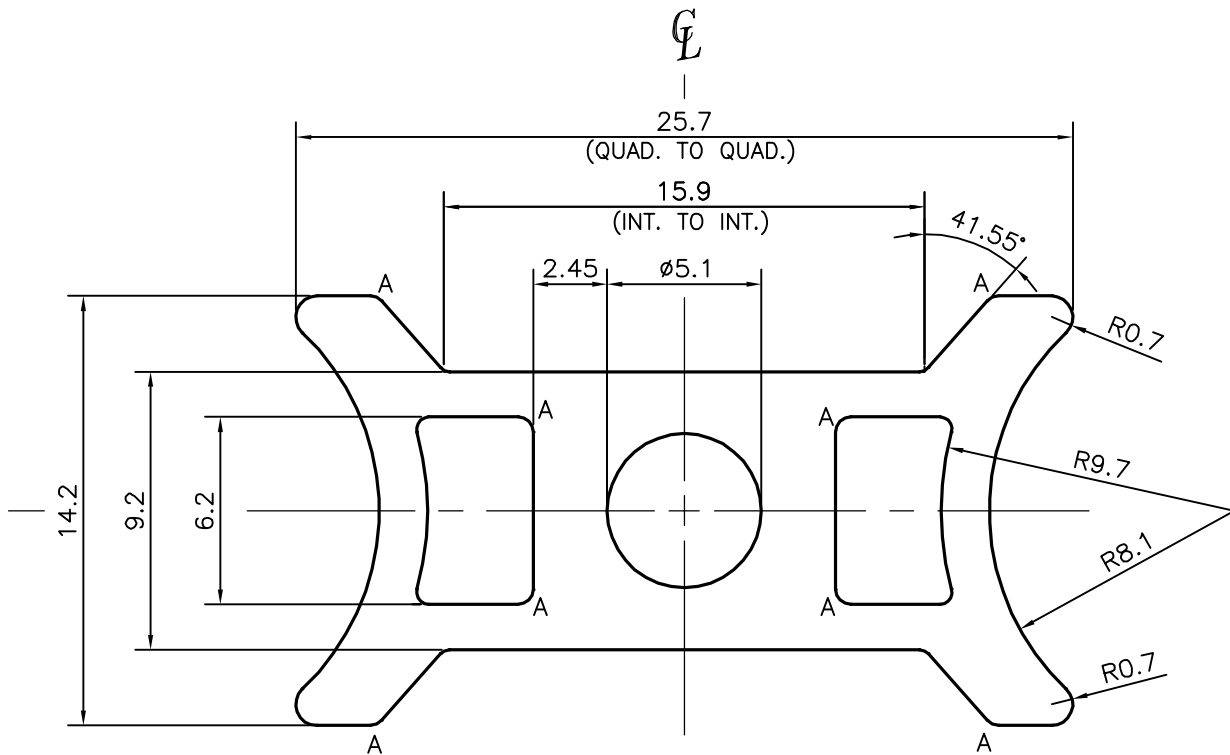

A = 0.50 mm RADIUS (8 PLACES)

TOLERANCES ON OVERALL WIDTHS & WIDTHS ACROSS FLATS OF BARS, & REGULAR SECTIONS

UPTO 6.40mm - ± 0.20	UPTO 32.0mm - ± 0.38	UPTO 120.0mm - ± 0.85	UPTO 320.00mm - ± 1.70
UPTO 10.0mm - ± 0.23	UPTO 50.0mm - ± 0.46	UPTO 160.0mm - ± 1.02	
UPTO 12.0mm - ± 0.25	UPTO 60.0mm - ± 0.53	UPTO 200.0mm - ± 1.14	
UPTO 16.0mm - ± 0.28	UPTO 80.0mm - ± 0.69	UPTO 250.0mm - ± 1.40	
UPTO 25.0mm - ± 0.30	UPTO 100.0mm - ± 0.75	UPTO 300.0mm - ± 1.65	

SYMBOL OF QUALITY
AN ISO 9001 COMPANY**JINDAL ALUMINIUM LTD.**
BANGALORE-560073 (INDIA)

	NAME	DATE
DRAWN	SRIVATHSA	12-07-2013
CHECKED		
APPROVED	S.S.GARG	22-07-2013

- ALL DIMENSIONS ARE IN mm.
- ROUND OFF ALL SHARP CORNERS WITH 0.40 mm.
- TOLERANCES WILL BE AS PER IS:6477-1983, UNLESS OTHERWISE SPECIFIED

SCALE	4:1
AREA mm ²	161.956
PERIMETER mm.	85.967
WEIGHT kg/m	0.437

PARTY'S NAME	DISHA RETAIL FIXTURES PVT. LTD., BANGALORE	DRAWING No.	P-12899	SECTION No.	-
PARTY'S DRAWING No.	DRF-02819-001		S3808		S3808
ALLOY & TEMPER	HE9 WP		25247		25247
DESCRIPTION	MISC. SECTION				