

P-13028

X1692

25259

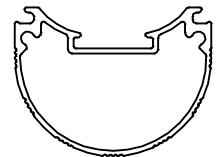

SCALE: - 1:1

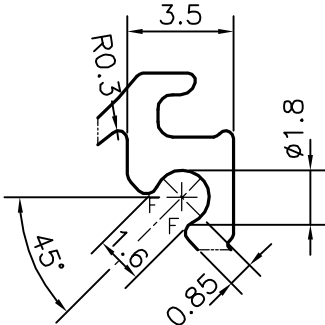
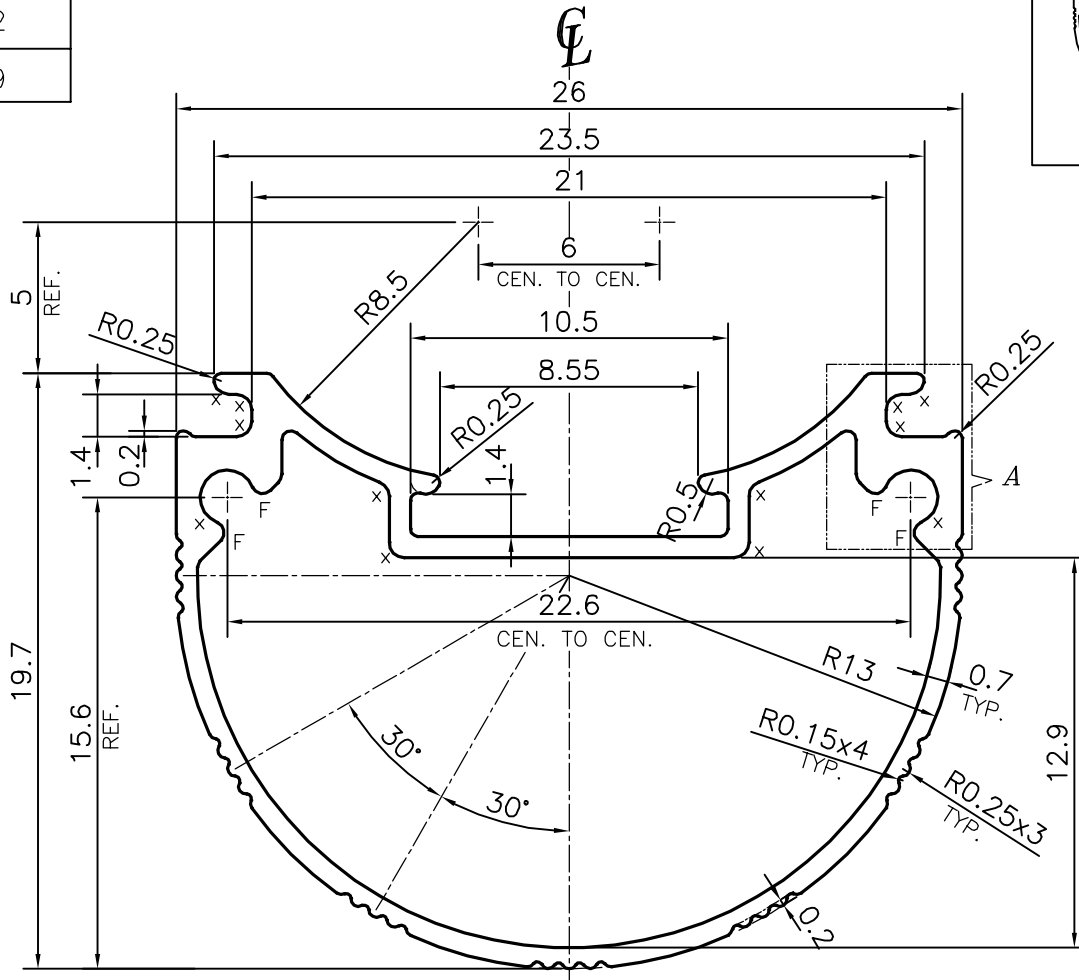

DETAIL OF "A"  
SCALE 4:1

ISSUE-2 :-

- 👉 DRAWING MODIFIED AS PER CUSTOMER'S REQUIREMENT.
- 👉 WEIGHT ALSO CHANGED FROM 0.179 TO 0.183 Kg/M

X = RADIUS 0.5 mm. (12 PLACES)  
F = FULL RADIUS (4 PLACES)

TOLERANCES ON OVERALL WIDTHS & WIDTHS ACROSS FLATS OF BARS, & REGULAR SECTIONS

|                     |                      |                      |   |
|---------------------|----------------------|----------------------|---|
| UPTO 6.40mm - ±0.20 | UPTO 32.0mm - ±0.38  | UPTO 120.0mm - ±0.85 | 1. STRAIGHTNESS=1.7mm/M<br>2. TWIST=1.7mm/M<br>3. ANGULARITY= ±2°<br>4. FLATNESS =0.007xWIDTH |
| UPTO 10.0mm - ±0.23 | UPTO 50.0mm - ±0.46  | UPTO 160.0mm - ±1.02 |   |
| UPTO 12.0mm - ±0.25 | UPTO 60.0mm - ±0.53  | UPTO 200.0mm - ±1.14 |   |
| UPTO 16.0mm - ±0.28 | UPTO 80.0mm - ±0.69  | UPTO 250.0mm - ±1.40 |   |
| UPTO 25.0mm - ±0.30 | UPTO 100.0mm - ±0.75 | UPTO 300.0mm - ±1.65 |   |



SYMBOL OF QUALITY  
AN ISO 9001 COMPANY

**JINDAL ALUMINIUM LTD.**  
BANGALORE-560073 (INDIA)

|                      |                |            |
|----------------------|----------------|------------|
|                      | NAME           | DATE       |
| DRAWN                | PARVESH        | 02-06-2014 |
| CHECKED              |                |            |
| APPROVED             | S.S.GARG       | 04-06-2014 |
| SCALE                |                | 4:1        |
| AREA mm <sup>2</sup> |                | 67.694     |
| PERIMETER mm.        |                | 97.243     |
| WEIGHT kg/m          |                | 0.183      |
| DRAWING No.          | SECTION No.    |            |
| P-13028              | -              |            |
| X1692                | X1692(ISSUE-2) |            |
| 25259                | 25259          |            |

1. ALL DIMENSIONS ARE IN mm.
2. ROUND OFF ALL SHARP CORNERS WITH 0.25 mm.
3. TOLERANCES WILL BE AS PER IS:6477-1983 , UNLESS OTHERWISE SPECIFIED

|                     |   |
|---------------------|---|
| PARTY'S NAME        | SEMTRONICS MICRO SYSTEMS PVT. LTD., BANGALORE |
| PARTY'S DRAWING No. | 600001  |
| ALLOY & TEMPER      | 63400 WP                                      |
| DESCRIPTION         | TUBE LIGHT SECTION                            |