

P-11800-1

E0062

25261

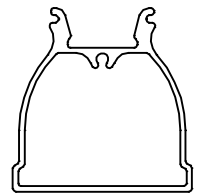
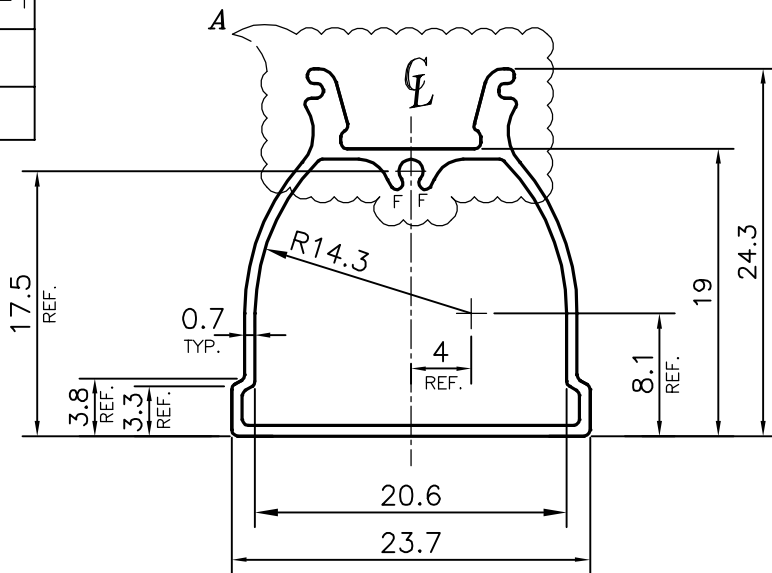

SCALE :- 1:1

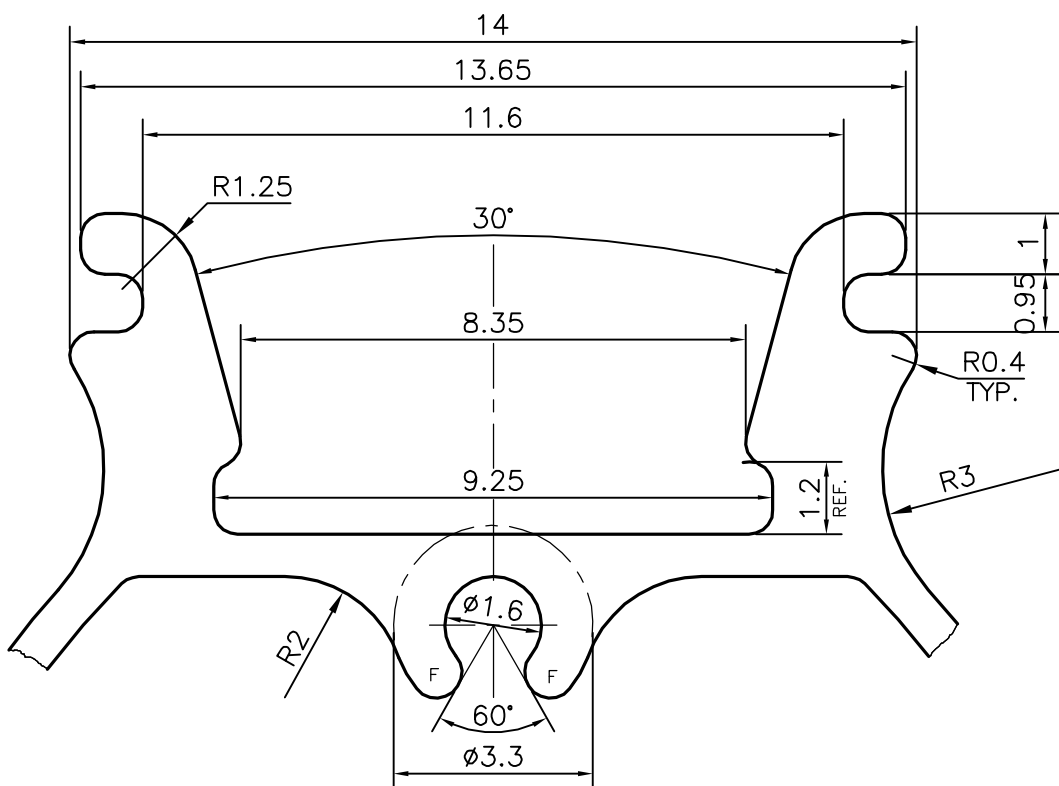

DETAIL OF "A"  
SCALE 8:1

F = FULL RADIUS (2 PLACES)



SYMBOL OF QUALITY  
AN ISO 9001 COMPANY

**JINDAL ALUMINIUM LTD.**  
BANGALORE-560073 (INDIA)

	NAME	DATE
DRAWN	PARVESH	24-08-2012
CHECKED		
APPROVED	S.S.GARG	30-10-2012
SCALE		2:1
AREA mm <sup>2</sup>		77.554
PERIMETER mm.		100.827
WEIGHT kg/m		0.209
DRAWING No.	SECTION No.	
P-11800-1	-	
E0062	E0062	
25261	25261	

1. ALL DIMENSIONS ARE IN mm.
2. ROUND OFF ALL SHARP CORNERS WITH 0.40 mm.
3. TOLERANCES WILL BE AS PER IS:6477-1983, UNLESS OTHERWISE SPECIFIED

PARTY'S NAME	STELLAR GREENTECH PVT. LTD., GURGAON
PARTY'S DRAWING No.	AS PER SAMPLE & REQUIREMENT
ALLOY & TEMPER	6063 T6
DESCRIPTION	TUBE LIGHT SECTION