

P-12004

E0063

25262

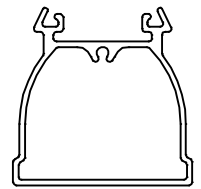

SCALE :- 1:1

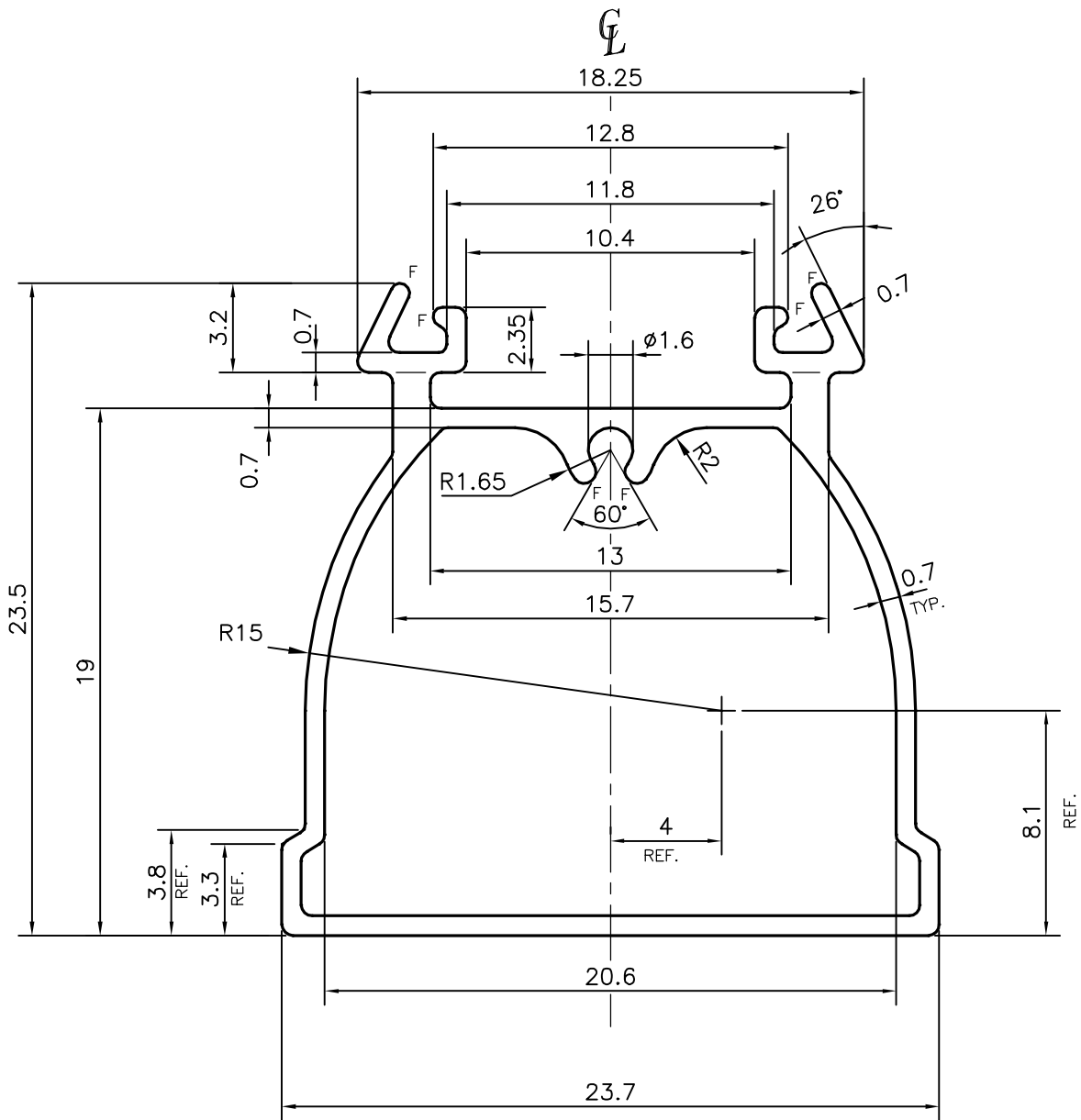

F = FULL RADIUS (6 PLACES)



SYMBOL OF QUALITY
AN ISO 9001 COMPANY

JINDAL ALUMINIUM LTD.
BANGALORE-560073 (INDIA)

	NAME	DATE
DRAWN	J.P.KAUSHIK	24-08-2012
CHECKED		
APPROVED	S.S.GARG	10-11-2012
SCALE		4:1
AREA mm ²		75.954
PERIMETER mm.		112.069
WEIGHT kg/m		0.205
DRAWING No.	SECTION No.	
P-12004	-	
E0063	E0063	
25262	25262	

1. ALL DIMENSIONS ARE IN mm.
2. ROUND OFF ALL SHARP CORNERS WITH 0.40 mm.
3. TOLERANCES WILL BE AS PER BS:EN-755-9, UNLESS OTHERWISE SPECIFIED

PARTY'S NAME	STELLAR GREENTECH PVT. LTD., GURGAON
PARTY'S DRAWING No.	AS PER SAMPLE & REQUIREMENT
ALLOY & TEMPER	6063 T6
DESCRIPTION	TUBE LIGHT SECTION