

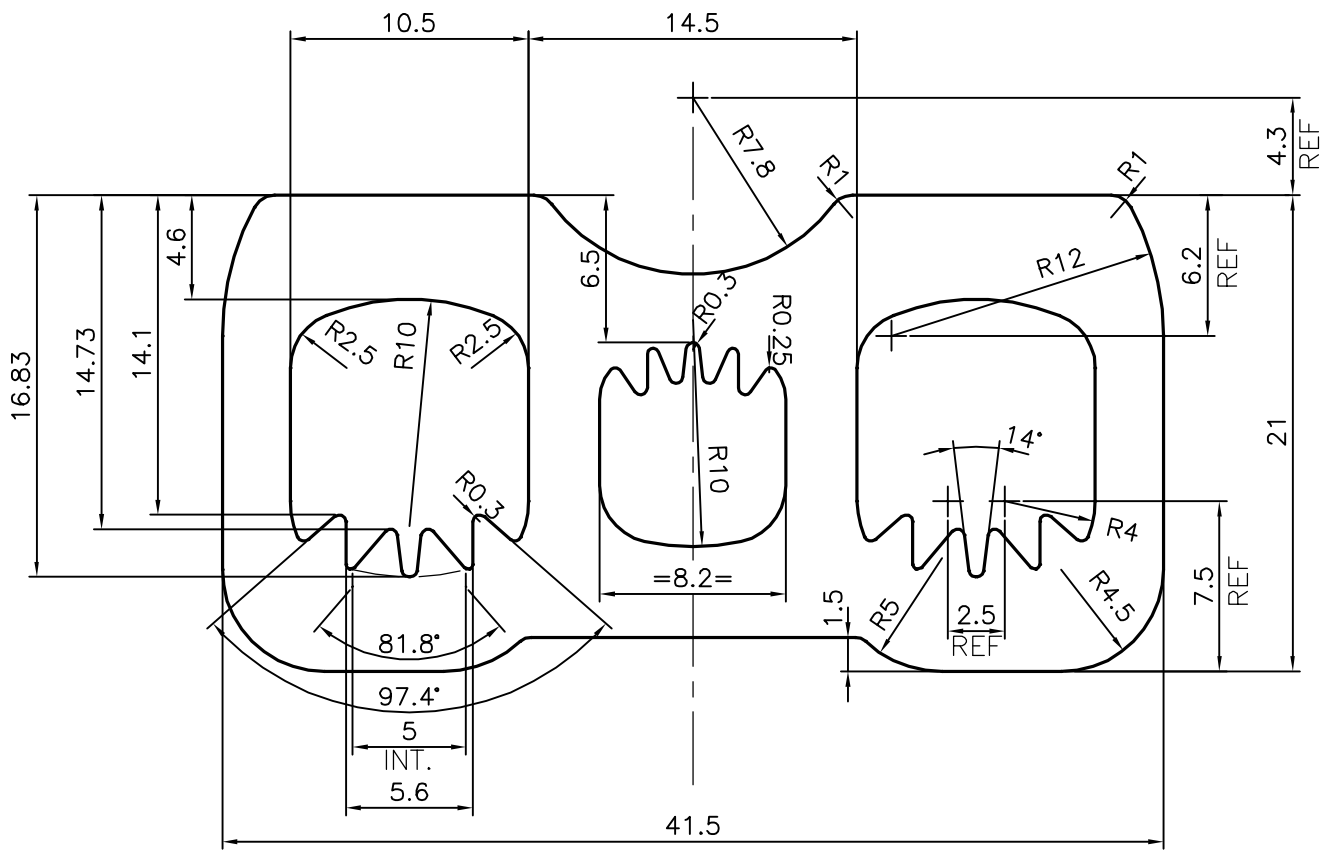

P-13232-2
S3951
25275

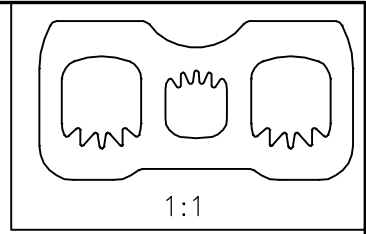
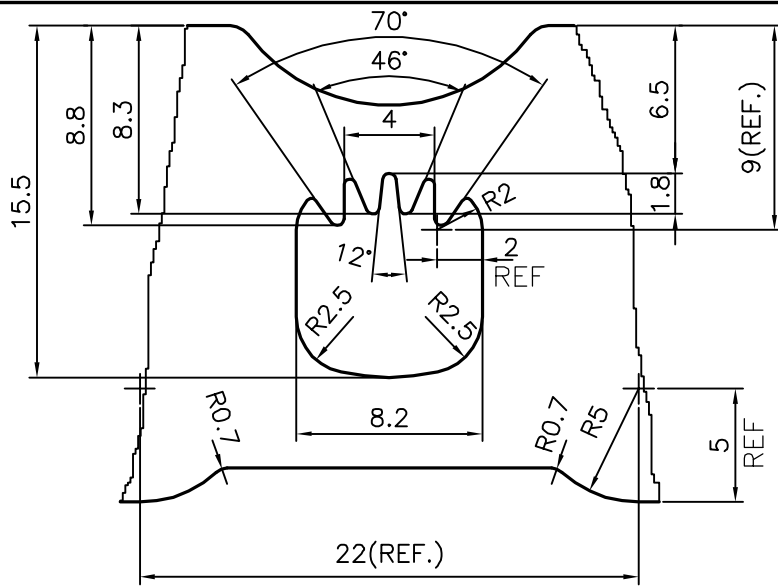

TOLERANCES ON OVERALL WIDTHS & WIDTHS ACROSS FLATS OF BARS, & REGULAR SECTIONS

UPTO 6.40mm - ±0.20	UPTO 32.0mm - ±0.38	UPTO 120.0mm - ±0.85	UPTO 320.00mm - ±1.70
UPTO 10.0mm - ±0.23	UPTO 50.0mm - ±0.46	UPTO 160.0mm - ±1.02	
UPTO 12.0mm - ±0.25	UPTO 60.0mm - ±0.53	UPTO 200.0mm - ±1.14	
UPTO 16.0mm - ±0.28	UPTO 80.0mm - ±0.69	UPTO 250.0mm - ±1.40	
UPTO 25.0mm - ±0.30	UPTO 100.0mm - ±0.75	UPTO 300.0mm - ±1.65	

 SYMBOL OF QUALITY AN ISO 9001 COMPANY	JINDAL ALUMINIUM LTD. BANGALORE-560073 (INDIA)	DRAWN	J.P.KAUSHIK	DATE	16-12-2013
		CHECKED			
1. ALL DIMENSIONS ARE IN mm. 2. ROUND OFF ALL SHARP CORNERS WITH 0.30 mm. 3. TOLERANCES WILL BE AS PER IS:6477-1983, UNLESS OTHERWISE SPECIFIED		APPROVED	S.S.GARG		17-12-2013
		SCALE			3:1
PARTY'S NAME SICAME INDIA CONNECTORS PVT. LTD., CHENNAI		AREA mm ²			527.33
		PERIMETER mm.			121.075
PARTY'S DRAWING No. F10086937		WEIGHT kg/m			1.424
		DRAWING No.	P-13232-2	SECTION No.	-
ALLOY & TEMPER 6106T6			S3951		S3951
			25275		25275
DESCRIPTION MISC. SECTION					