

P-12061

S3646

25286

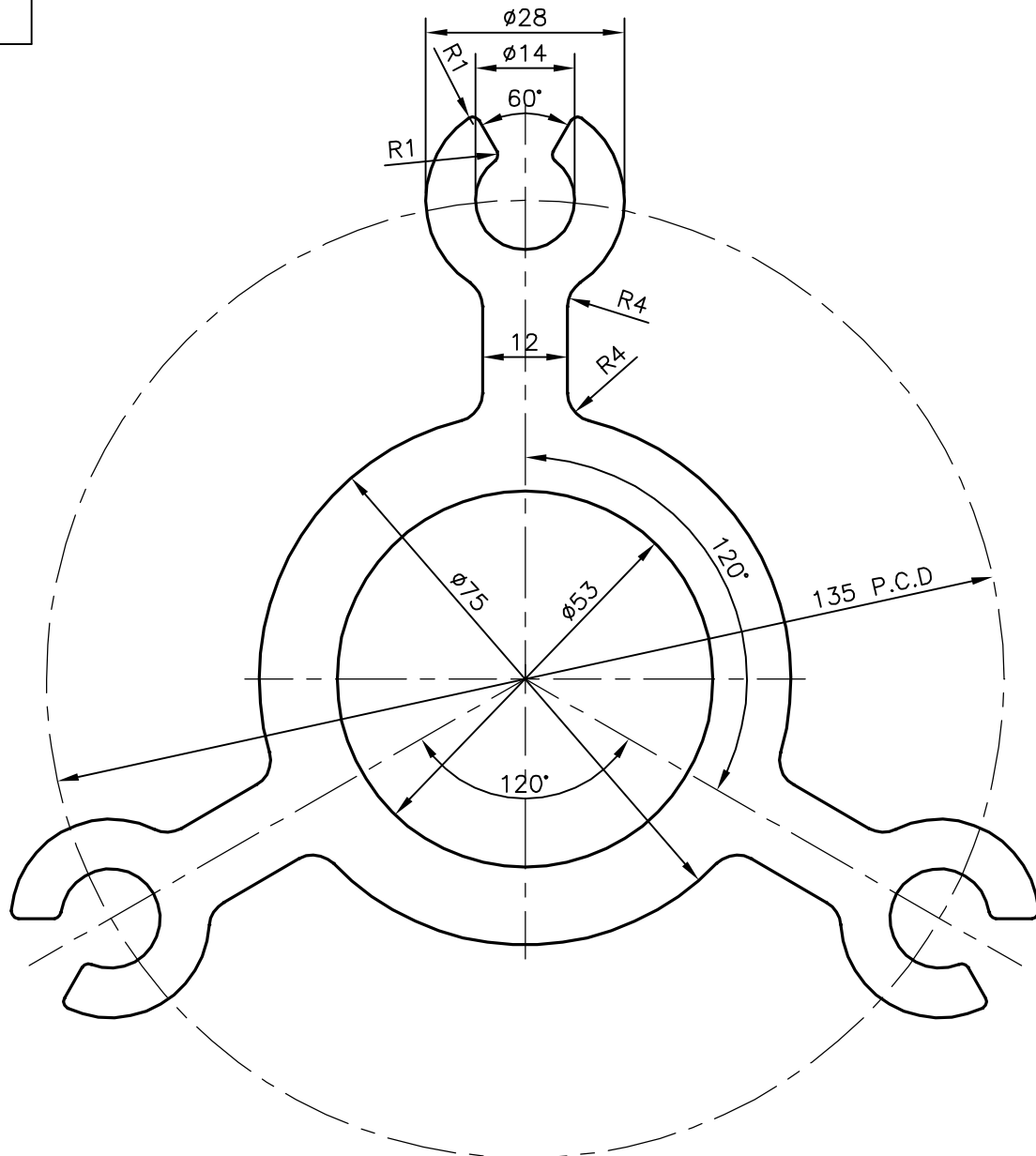

SYMBOL OF QUALITY  
AN ISO 9001 COMPANY

**JINDAL ALUMINIUM LTD.**  
BANGALORE-560073 (INDIA)

	NAME	DATE
DRAWN	RAGHAVENDRA	22-09-2012
CHECKED		
APPROVED	J.N.RAI	08-02-2013
SCALE		1:1
AREA mm <sup>2</sup>		3978.392
PERIMETER mm.		627.184
WEIGHT kg/m		10.742
DRAWING No.	SECTION No.	
P-12061	-	
S3646	S3646	
25286	25286	

1. ALL DIMENSIONS ARE IN mm.
2. ROUND OFF ALL SHARP CORNERS WITH 0.40 mm.
3. TOLERANCES WILL BE AS PER BS:EN-755-9 UNLESS OTHERWISE SPECIFIED

PARTY'S NAME ALSTOM T&D INDIA LIMITED, CHENNAI

PARTY'S DRAWING No. SU-5823 & Y-2121

ALLOY & TEMPER 6060 T6

DESCRIPTION/END USE ROTATING BASE SUPPORT SECTION