

P-14585-1

S4462

25293

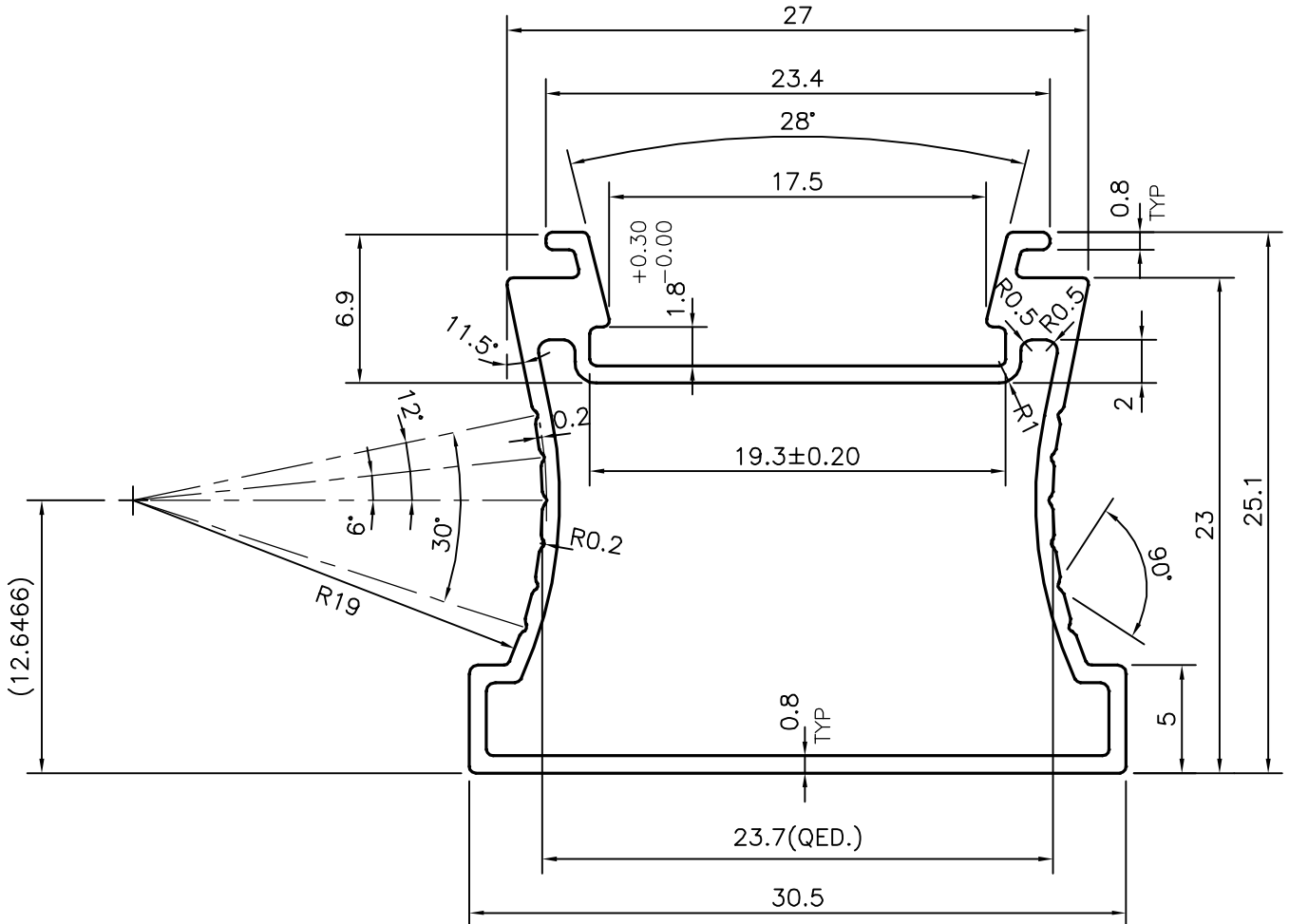
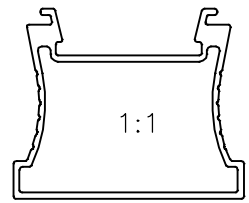

ISSUE-2 :-

SHAPE CHANGED.

WEIGHT ALSO CHANGED FROM 0.254 kg/m TO 0.284 kg/m



SYMBOL OF QUALITY
AN ISO 9001 COMPANY

JINDAL ALUMINIUM LTD.
BANGALORE-560073 (INDIA)

	NAME	DATE
DRAWN	J.P.KAUSHIK	02-05-2016
CHECKED		
APPROVED	S.S. GARG	03-05-2016
SCALE		3:1
AREA mm ²		105.226
PERIMETER mm.		130.777
WEIGHT kg/m		0.284
DRAWING No.	SECTION No.	
P-14585-1	-	
S4462	S4462(ISSUE-2)	
25293	25293	

1. ALL DIMENSIONS ARE IN mm.
2. ROUND OFF ALL SHARP CORNERS WITH 0.30 mm.
3. TOLERANCES WILL BE AS PER IS:6477-1983 UNLESS OTHERWISE SPECIFIED

PARTY'S NAME	ARKA TECHNOLOGIES PVT. LTD., BANGALORE
PARTY'S DRAWING No.	AS PER SAMPLE
ALLOY & TEMPER	HE9 WP
DESCRIPTION	TUBE LIGHT SECTION