

P-14021-1

S4265

25301

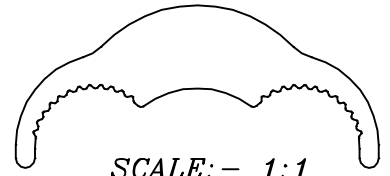

SCALE: - 1:1

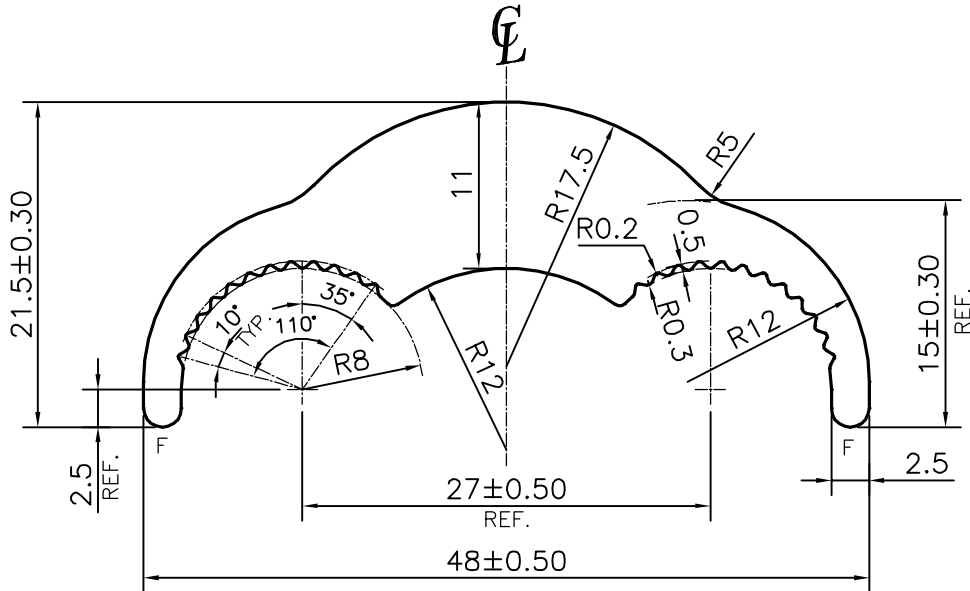

F = FULL RADIUS (2 PLACES)

TOLERANCE CHART CD = CIRCUMSCRIBING CIRCLE

DIMENSION	CD≤100	100<CD≤200	200<CD≤300	300<CD≤500
UPTO 10mm	±0.25	±0.30	±0.35	±0.40
10.0 - 25.0	±0.30	±0.40	±0.50	±0.60
25.0 - 50.0	±0.50	±0.60	±0.80	±0.90
50.0 - 100	±0.70	±0.90	±1.10	±1.30
100 - 150	-	±1.10	±1.30	±1.50
150 - 200	-	±1.3	±1.50	±1.80
200 - 300	-	-	±1.70	±2.10
300 - 450	-	-	-	±2.80



SYMBOL OF QUALITY
AN ISO 9001 COMPANY

JINDAL ALUMINIUM LTD.
BANGALORE-560073 (INDIA)

	NAME	DATE
DRAWN	PARVESH	09-10-2014
CHECKED		
APPROVED	S.S.GARG	10-10-2014

- ALL DIMENSIONS ARE IN mm.
- ROUND OFF ALL SHARP CORNERS WITH 0.50 mm.
- TOLERANCES WILL BE AS PER BS:EN-755-9 , UNLESS OTHERWISE SPECIFIED

SCALE	2:1
AREA mm ²	371.022
PERIMETER mm.	143.645
WEIGHT kg/m	1.002

PARTY'S NAME	SICAME INDIA CONNECTORS PVT. LTD., KANCHIPURAM
PARTY'S DRAWING No.	AS PER AUTOCAD DRAWING-F10084415 A
ALLOY & TEMPER	6005 T6
DESCRIPTION	INDUSTRIAL SECTION-UPPER BODY

DRAWING No.	SECTION No.
P-14021-1	-
S4265	S4265
25301	25301