

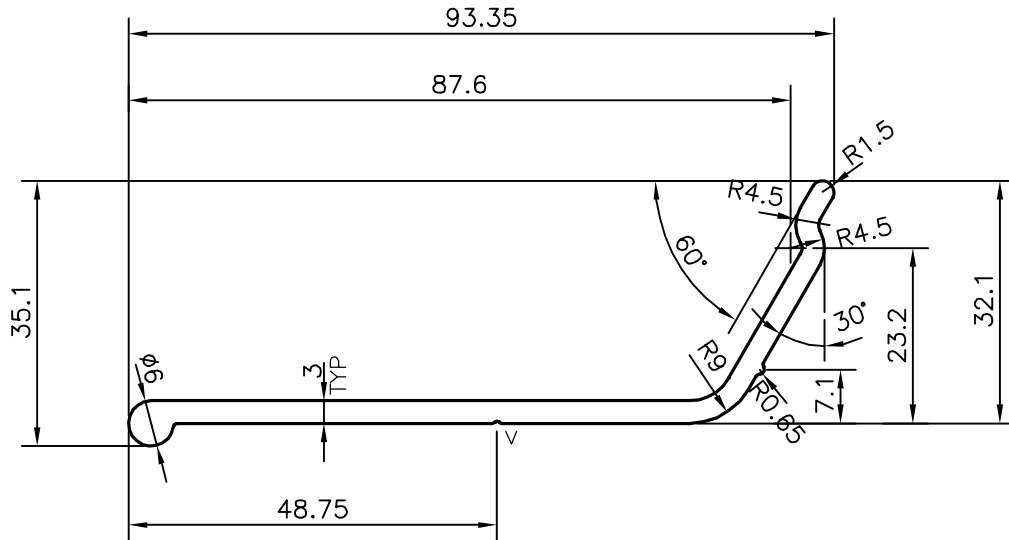

P-14889

S4550

25335



V = V GROOVE 0.3x90°

 SYMBOL OF QUALITY AN ISO 9001 COMPANY	<b>JINDAL ALUMINIUM LTD.</b> BANGALORE-560073 (INDIA)	NAME		DATE
		DRAWN	J.P.KAUSHIK	16-07-2015
1. ALL DIMENSIONS ARE IN mm. 2. ROUND OFF ALL SHARP CORNERS WITH 0.40 mm. 3. TOLERANCES WILL BE AS PER IS:3965-1981 , UNLESS OTHERWISE SPECIFIED		CHECKED		
		APPROVED	S.S.GARG	25-07-2015
PARTY'S NAME ENERCON ASIA PACIFIC SYSTEMS. PVT. LTD., HOSUR		SCALE		1:1
		AREA mm <sup>2</sup>		348.357
PARTY'S DRAWING No. AL7146-02		PERIMETER mm.		231.797
		WEIGHT kg/m		0.941
ALLOY & TEMPER 6063 T6		DRAWING No.		SECTION No.
		P-14889		-
DESCRIPTION MISC. SECTION		S4550		S4550
		25335		25335