

P-15375

S4760

25346

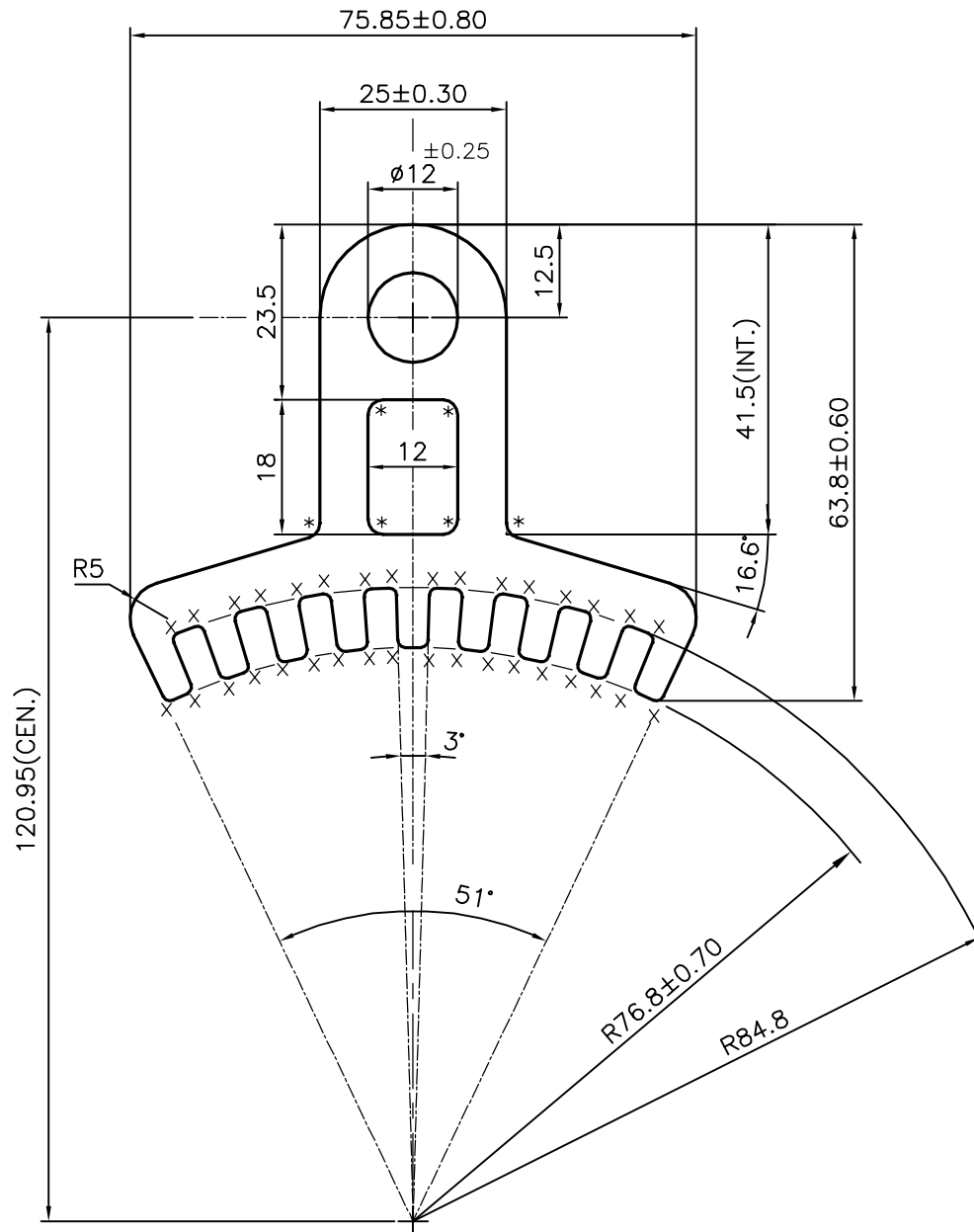

x = 1.0 RADIUS(34 PLACES)

* = 2.0 RADIUS (6 PLACES)



SYMBOL OF QUALITY
AN ISO 9001 COMPANY

JINDAL ALUMINIUM LTD.
BANGALORE-560073 (INDIA)

	NAME	DATE
DRAWN	J.P.KAUSHIK	28-11-2015
CHECKED		
APPROVED	S.S.GARG	09-12-2015

1. ALL DIMENSIONS ARE IN mm.
2. ROUND OFF ALL SHARP CORNERS WITH 0.40 mm.
3. TOLERANCES WILL BE AS PER IS:6477-1983 UNLESS OTHERWISE SPECIFIED

SCALE	1:1
AREA mm ²	1510.297
PERIMETER mm.	364.764
WEIGHT kg/m	4.078

PARTY'S NAME IEEC POWER ELECTRONICS PVT. LTD., MUMBAI

DRAWING No. SECTION No.

PARTY'S DRAWING No. A-6320-03

P-15375

S4760

25346

-

S4760

25346

ALLOY & TEMPER 6063 T6

DESCRIPTION 147.6 ROLLER 9 FIN ELECTRODE PROFILE