

P-15609

S4854

25352

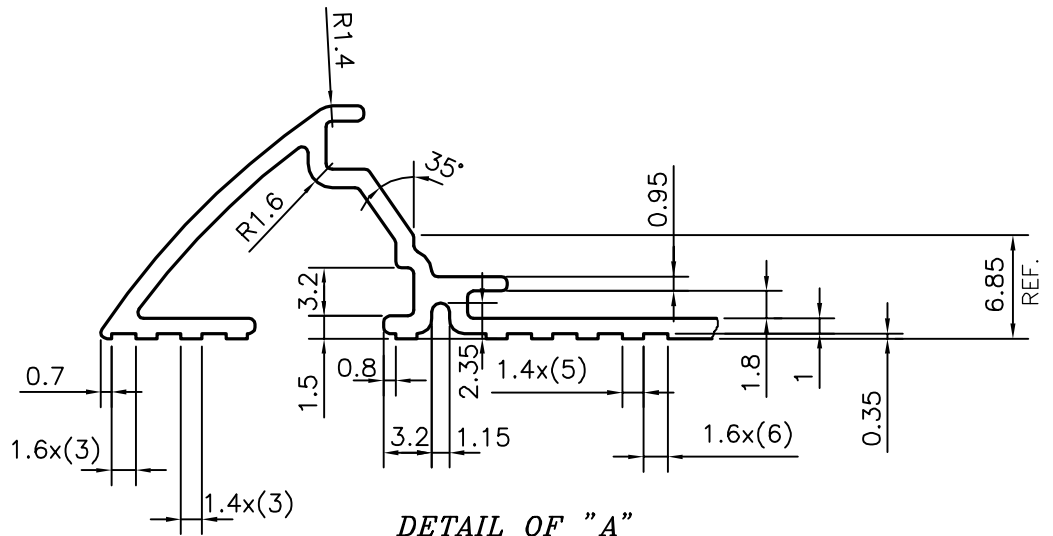

DETAIL OF "A"
SCALE 2:1

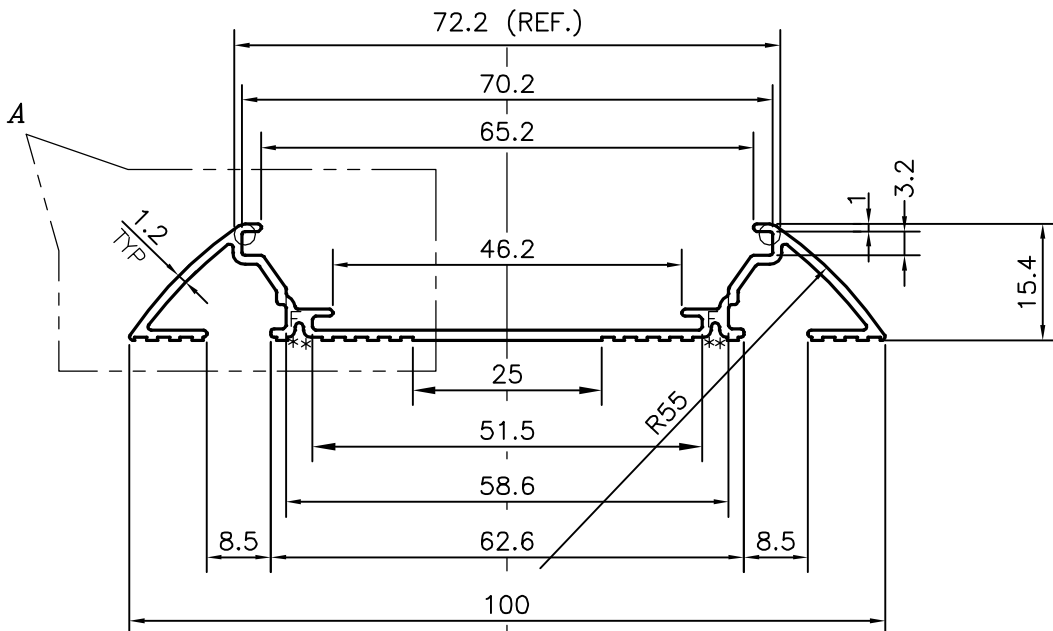

F = FULL RADIUS (2 PLACES)
* = 1.0 RADIUS (4 PLACES)

 SYMBOL OF QUALITY AN ISO 9001 COMPANY	JINDAL ALUMINIUM LTD. BANGALORE-560073 (INDIA)	NAME	DATE
		DRAWN	J.P.KAUSHIK 19-02-2016
		CHECKED	
		APPROVED	S.S.GARG 23-02-2016
1. ALL DIMENSIONS ARE IN mm. 2. ROUND OFF ALL SHARP CORNERS WITH 0.40 mm. 3. TOLERANCES WILL BE AS PER IS:3965-1981, UNLESS OTHERWISE SPECIFIED		SCALE	1:1
		AREA mm ²	203.644
		PERIMETER mm.	339.085
		WEIGHT kg/m	0.550
PARTY'S NAME	ARKA TECHNOLOGIES PVT. LTD., BANGALORE	DRAWING No.	SECTION No.
PARTY'S DRAWING No.	MODIFIED OF SECTION No:-25243	P-15609	-
ALLOY & TEMPER	6063 T6	S4854	S4854
		25352	25352
DESCRIPTION	LED LIGHT SECTION		