

P-15706

S4881

X2083

25355

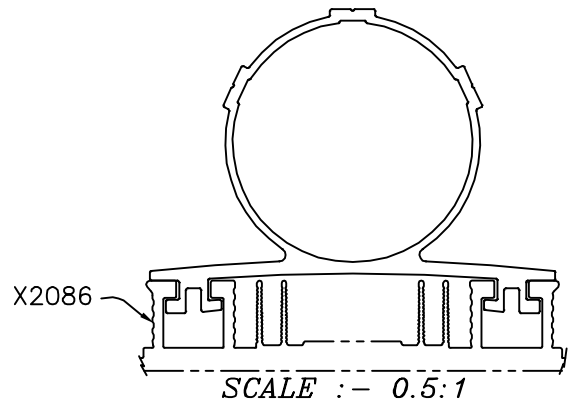
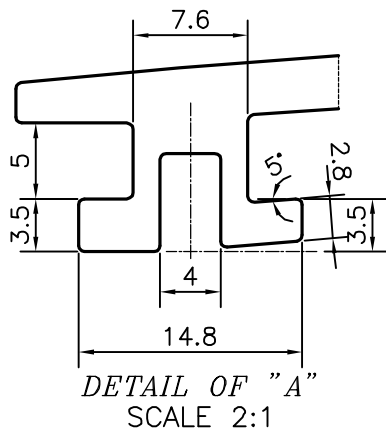
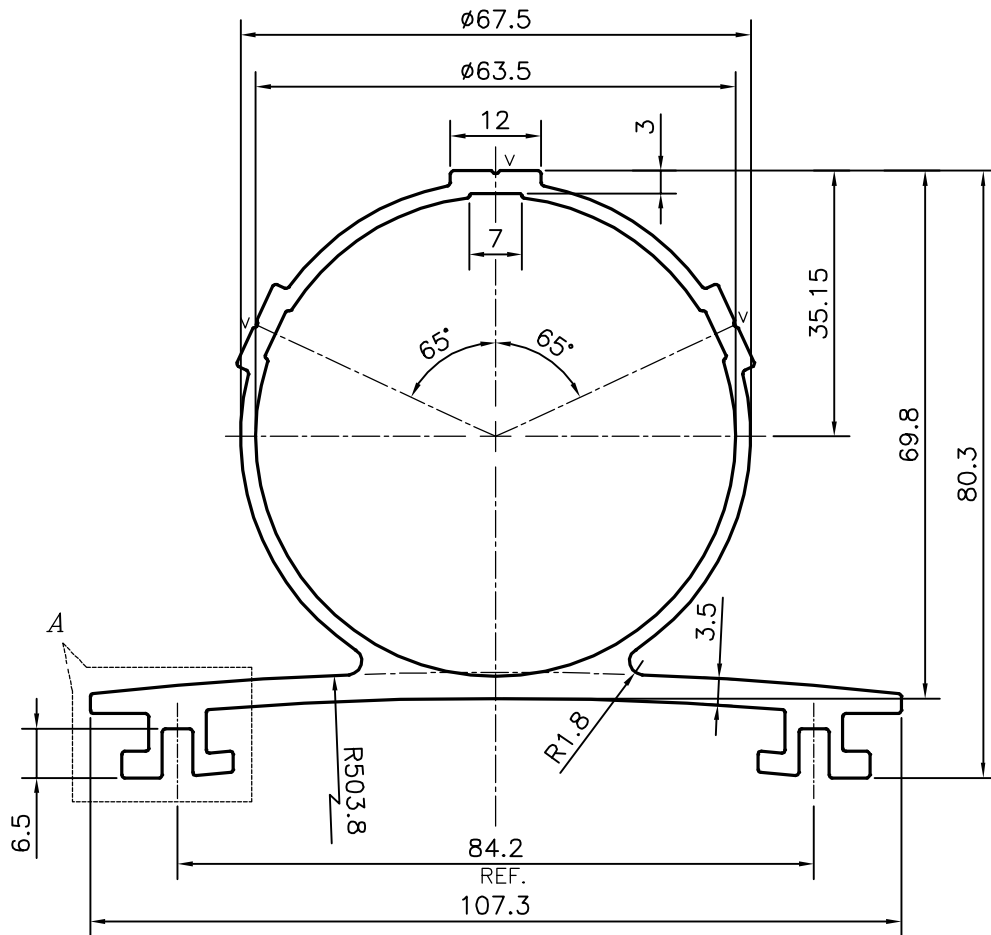

V = VEE GROOVE 0.4x90° (3 PLACES)



SYMBOL OF QUALITY  
AN ISO 9001 COMPANY

**JINDAL ALUMINIUM LTD.**  
BANGALORE-560073 (INDIA)

	NAME	DATE
DRAWN	PARVESH	22-03-2016
CHECKED		
APPROVED	B. NATARAJ	25-03-2016
SCALE		1:1
AREA mm <sup>2</sup>		921.573
PERIMETER mm.		457.634
WEIGHT kg/m		2.488
DRAWING No.	SECTION No.	
P-15706	-	
S4881	S4881	
X2083	X2083	
25355	25355	

1. ALL DIMENSIONS ARE IN mm.
2. ROUND OFF ALL SHARP CORNERS WITH 0.40 mm.
3. TOLERANCES WILL BE AS PER IS:6477-1983 , UNLESS OTHERWISE SPECIFIED

PARTY'S NAME	VYOMA LITS, BANGALORE
PARTY'S DRAWING No.	AS PER REQUIREMENT
ALLOY & TEMPER	HE9 WP
DESCRIPTION	ELECTRICAL SECTION