

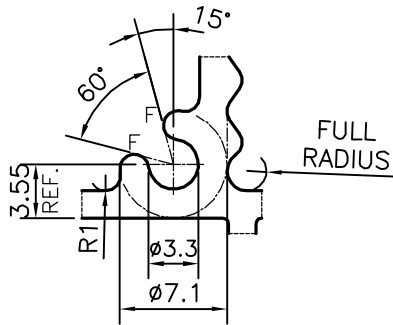

P-15707
S4882
X2084
25356

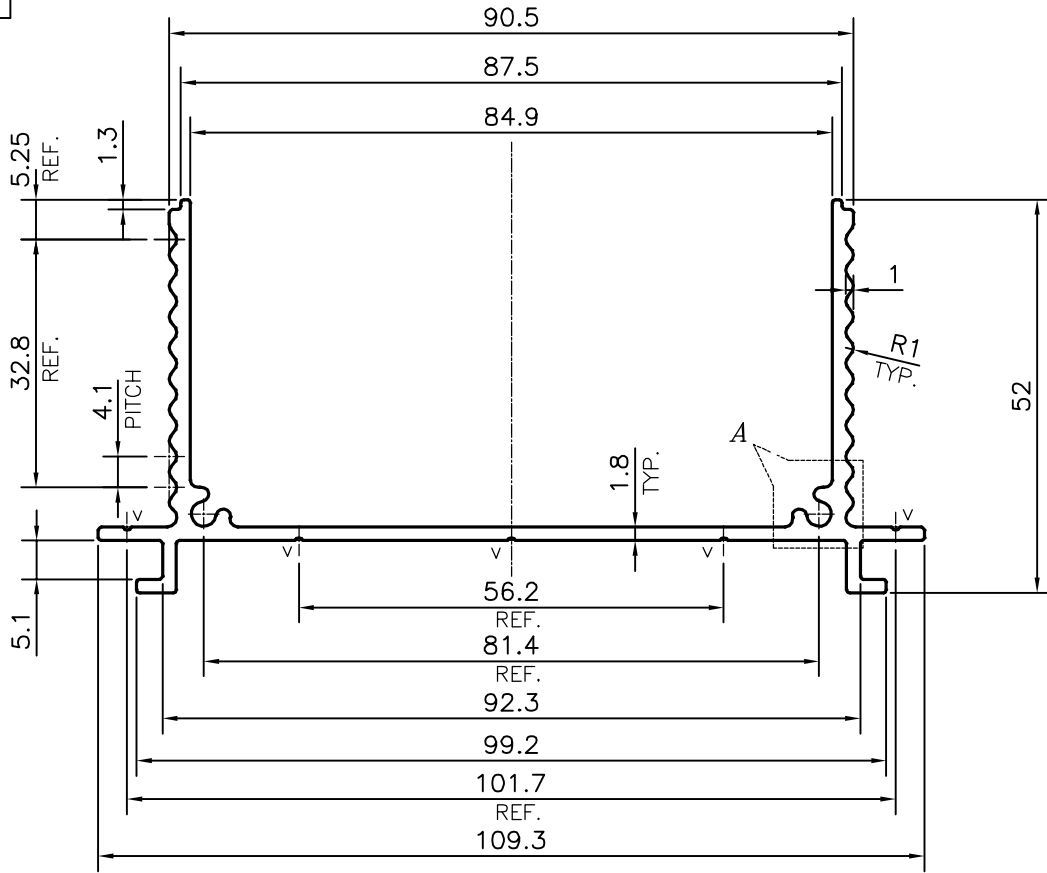

DETAIL OF "A"
SCALE 2:1

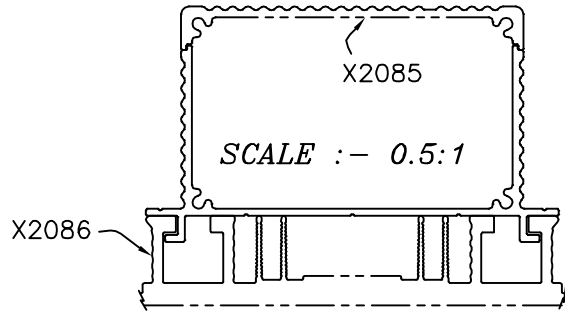

V = VEE GROOVE 0.4x90° (5 PLACES)
F = FULL RADIUS (4 PLACES)

 SYMBOL OF QUALITY AN ISO 9001 COMPANY	JINDAL ALUMINIUM LTD. BANGALORE-560073 (INDIA)	NAME	DATE
		DRAWN	PARVESH 29-03-2016
		CHECKED	
		APPROVED	B. NATARAJ 25-03-2016
		SCALE	1:1
		AREA mm ²	452.234
		PERIMETER mm.	455.202
		WEIGHT kg/m	1.221
PARTY'S NAME	VYOMA LITS, BANGALORE	DRAWING No.	SECTION No.
PARTY'S DRAWING No.	AS PER REQUIREMENT	P-15707	-
ALLOY & TEMPER	HE9 WP	S4882	S4882
		X2084	X2084
DESCRIPTION	ELECTRICAL SECTION	25356	25356