

P-16010
S4998
25361

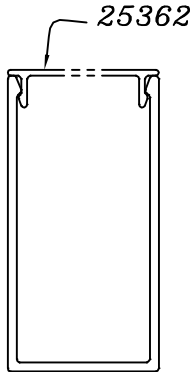
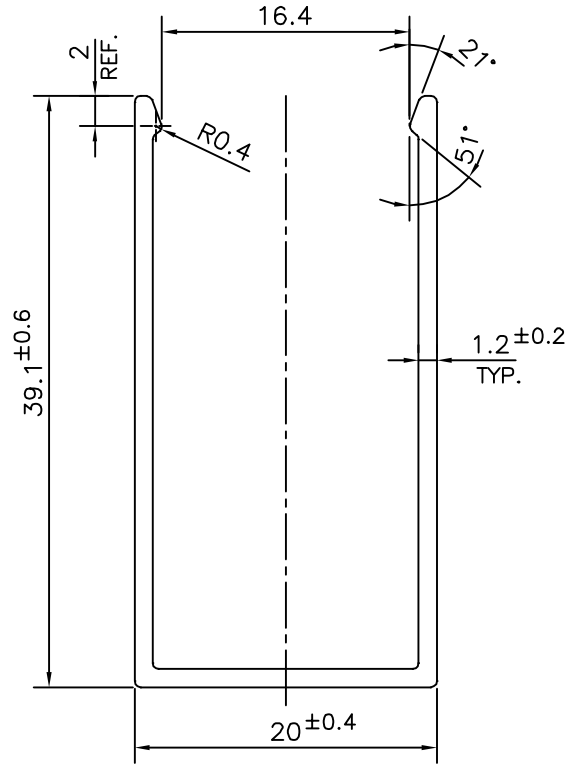
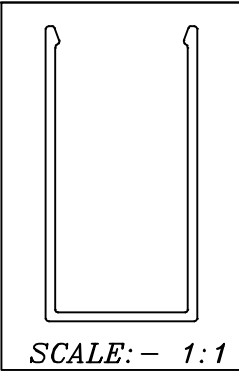

TOLERANCES ON OVERALL WIDTHS & WIDTHS ACROSS FLATS OF BARS, & REGULAR SECTIONS

UPTO 6.40mm - ±0.20	UPTO 32.0mm - ±0.38	UPTO 120.0mm - ±0.85	1. STRAIGHTNESS=1.7mm/M 2. TWIST=1.7mm/M 3. ANGULARITY= ±2° 4. FLATNESS =0.007xWIDTH
UPTO 10.0mm - ±0.23	UPTO 50.0mm - ±0.46	UPTO 160.0mm - ±1.02	
UPTO 12.0mm - ±0.25	UPTO 60.0mm - ±0.53	UPTO 200.0mm - ±1.14	
UPTO 16.0mm - ±0.28	UPTO 80.0mm - ±0.69	UPTO 250.0mm - ±1.40	
UPTO 25.0mm - ±0.30	UPTO 100.0mm - ±0.75	UPTO 300.0mm - ±1.65	

<p>SYMBOL OF QUALITY AN ISO 9001 COMPANY</p>	<p>JINDAL ALUMINIUM LTD. BANGALORE-560073 (INDIA)</p>	NAME	DATE
		DRAWN	PARVESH
		CHECKED	
		APPROVED	S.S. GARG
		SCALE	2:1
		AREA mm ²	116.36
		PERIMETER mm.	193.296
		WEIGHT kg/m	0.314
PARTY'S NAME	JAYABHERI PROPERTIES PVT.LTD., HYDERABAD	DRAWING No.	SECTION No.
PARTY'S DRAWING No.	GAPL/R.K./S4/0010	P-16010	-
ALLOY & TEMPER	6063 T6	S4998	S4998
DESCRIPTION	ELECTRICAL SECTION	25361	25361

- ALL DIMENSIONS ARE IN mm.
- ROUND OFF ALL SHARP CORNERS WITH 0.40 mm.
- TOLERANCES WILL BE AS PER IS:3965-1981, UNLESS OTHERWISE SPECIFIED