

P-15922

S4992

25366

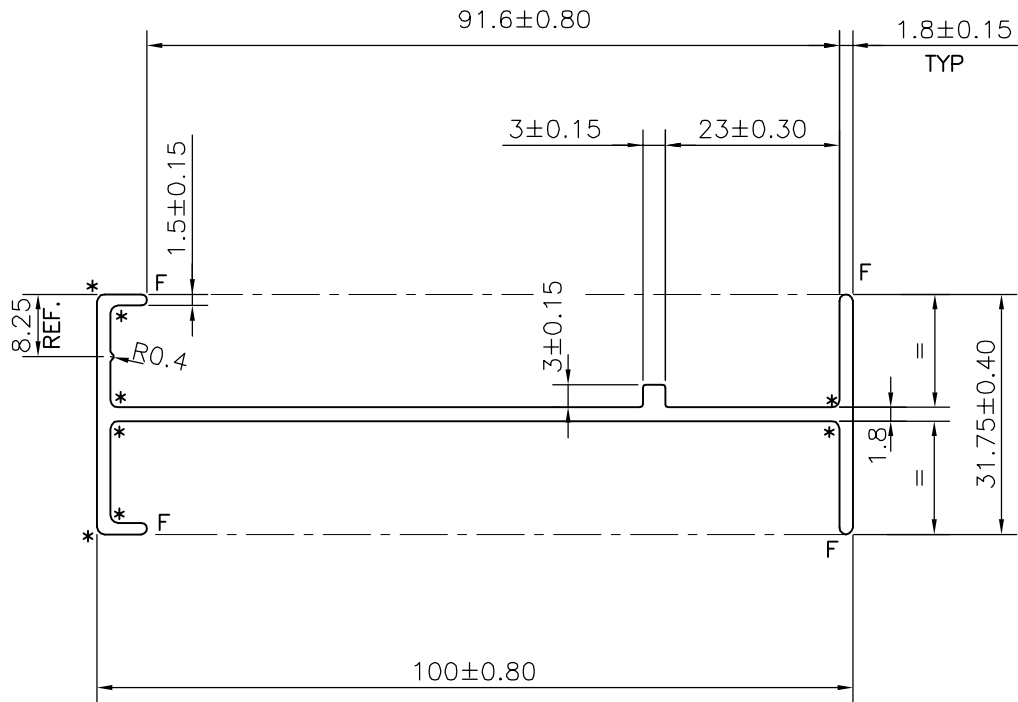

F = FULL RADIUS (4 PLACES)

\* = 1.0 RADIUS (8 PLACES)



SYMBOL OF QUALITY  
AN ISO 9001 COMPANY

**JINDAL ALUMINIUM LTD.**  
BANGALORE-560073 (INDIA)

	NAME	DATE
DRAWN	J.P.KAUSHIK	02-06-2016
CHECKED		
APPROVED	S.S. GARG	29-06-2016

1. ALL DIMENSIONS ARE IN mm.
2. ROUND OFF ALL SHARP CORNERS WITH 0.40 mm.
3. TOLERANCES WILL BE AS PER, IS:3965-1981 UNLESS OTHERWISE SPECIFIED

SCALE	1:1
AREA mm <sup>2</sup>	311.177
PERIMETER mm.	341.937
WEIGHT kg/m	0.840

PARTY'S NAME	IMPRES INDIA CABLE & PIPE SUPPORTS PVT. LTD., BANGALORE	DRAWING No.	P-15922	SECTION No.	-
PARTY'S DRAWING No.	AS PER DRAWING-51100		S4992		S4992
ALLOY & TEMPER	6063 T6		25366		25366
DESCRIPTION	LIGHT DUTY SIDE RAIL SECTION				