

P-19309

S6197

25392

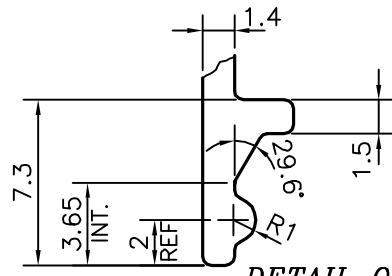

DETAIL OF "B"  
SCALE 2:1

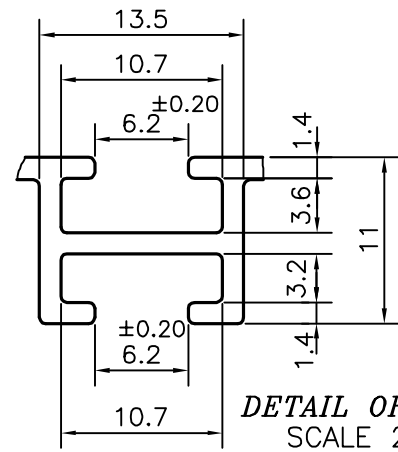

DETAIL OF "A"  
SCALE 2:1

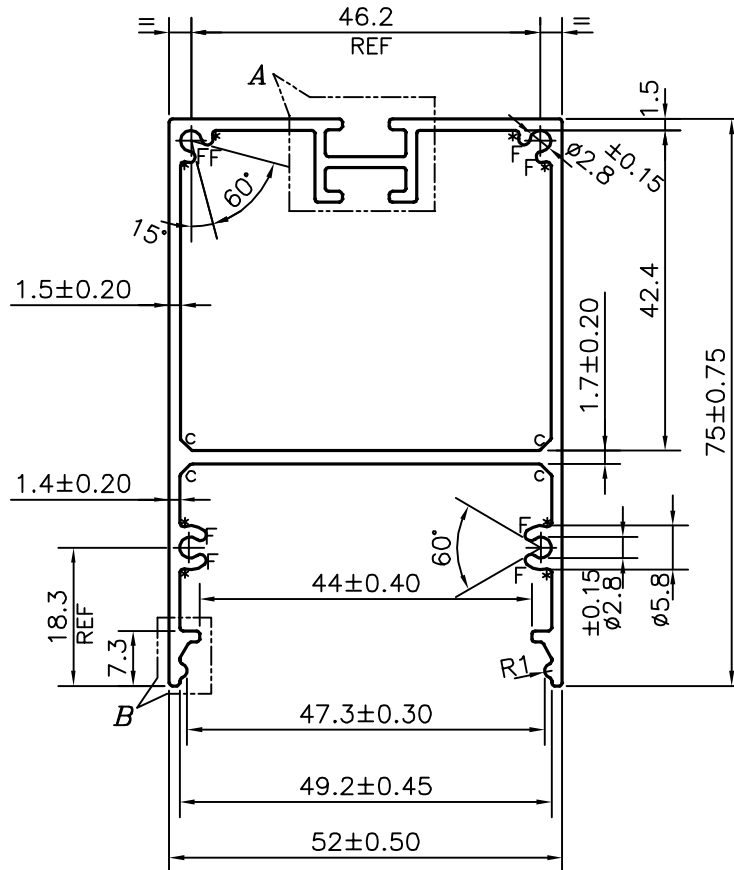

C = CHAMFER 1.5x45° (4 PLACES)

F = FULL RADIUS (8 PLACES)

\* = 0.50 RADIUS (8 PLACES)



SYMBOL OF QUALITY  
AN ISO 9001 COMPANY

**JINDAL ALUMINIUM LTD.**  
BANGALORE-560073 (INDIA)

	NAME	DATE
DRAWN	J.P.KAUSHIK	23-03-2019
CHECKED		
APPROVED	B.NATARAJA	02-04-2019
SCALE		1:1
AREA mm <sup>2</sup>		467.138
PERIMETER mm.		360.481
WEIGHT kg/m		1.261
DRAWING No.	SECTION No.	
P-19309	-	
S6197	S6197	
25392	25392	

1. ALL DIMENSIONS ARE IN mm.
2. ROUND OFF ALL SHARP CORNERS WITH 0.40 mm.
3. TOLERANCES WILL BE AS PER IS:6477-1983 , UNLESS OTHERWISE SPECIFIED

PARTY'S NAME	CHANDRA LAMP SHADES, BANGALORE
PARTY'S DRAWING No.	AS PER DRAWING
ALLOY & TEMPER	6063 T6
DESCRIPTION	MISC. SECTION