

7565

25720

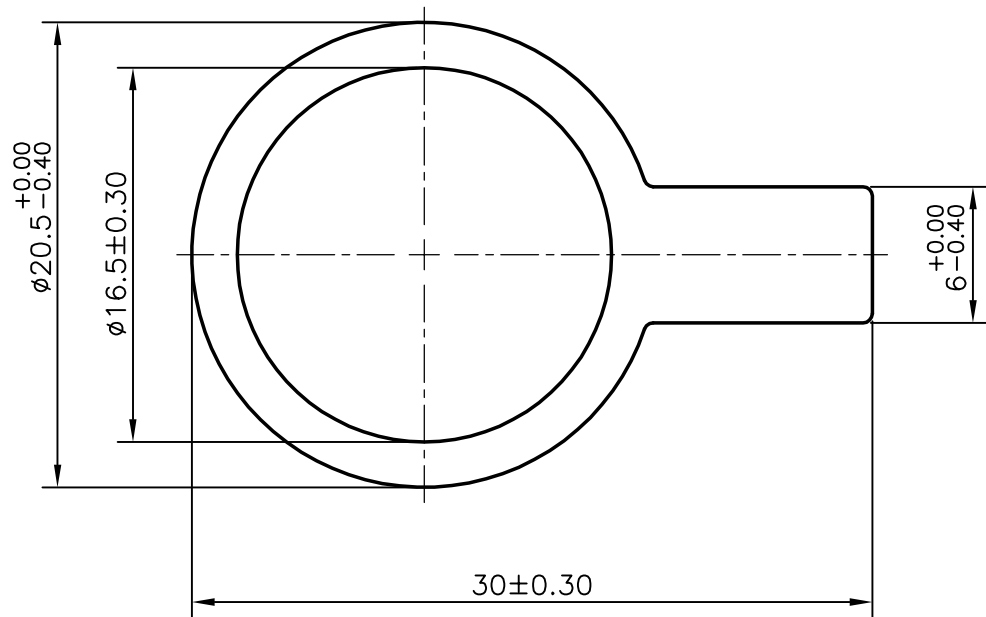
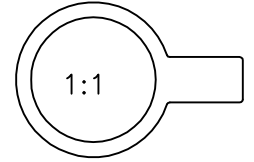

SYMBOL OF QUALITY  
AN ISO 9001 COMPANY

**JINDAL ALUMINIUM LTD.**  
**BANGALORE-560073 (INDIA)**

	NAME	DATE
DRAWN	J.P.KAUSHIK	18-07-2008
CHECKED		
APPROVED		

1. ALL DIMENSIONS ARE IN mm.
2. ROUND OFF ALL SHARP CORNERS WITH 0.40 mm.
3. TOLERANCES WILL BE AS PER IS:6477-1983 UNLESS OTHERWISE SPECIFIED

SCALE	3:1
AREA mm <sup>2</sup>	174.091
PERIMETER mm.	83.709
WEIGHT kg/m	0.468

PARTY'S NAME BHARAT ELECTRONICS LTD., BANGALORE

PARTY'S DRAWING No. 9000-000-657-21

ALLOY & TEMPER HE9 WP

DESCRIPTION PROFILE

DRAWING No.	SECTION No.
7565	7565
25720	25720