

N932

7604

25732

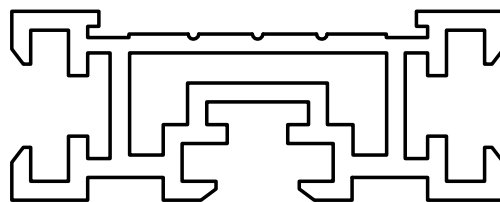

SCALE 1:1

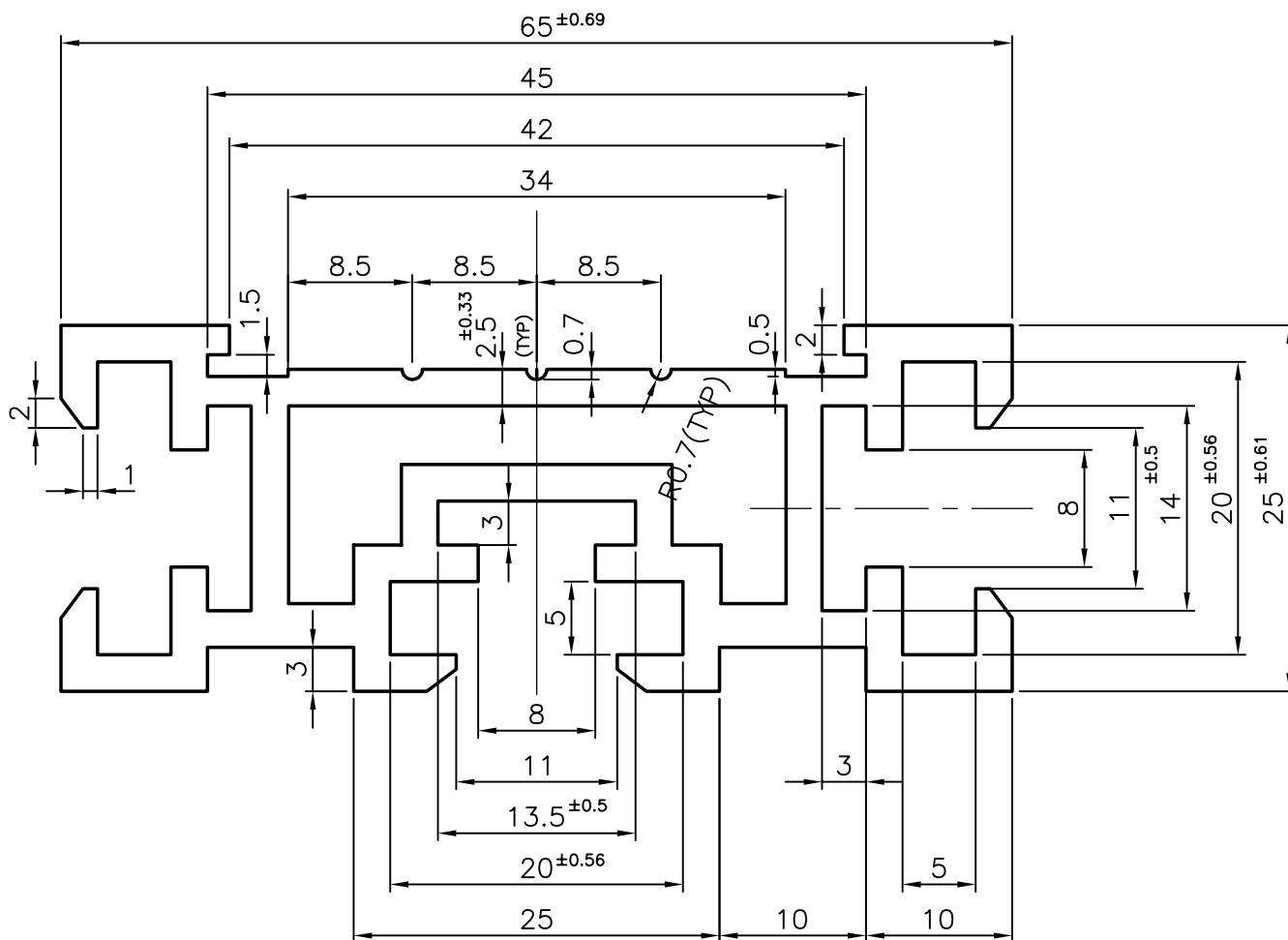

GENERAL WALL THICKNESS - $2.5^{±0.33}$ mm

 SYMBOL OF QUALITY AN ISO 9002 COMPANY	JINDAL ALUMINIUM LTD. BANGALORE-560073 (INDIA)		NAME	DATE
			DRAWN	R.D.SHARMA
1. ALL DIMENSIONS ARE IN mm. 2. ROUND OFF ALL SHARP CORNERS WITH 0.40 mm. 3. TOLERANCES WILL BE AS PER IS: 3965-1981, UNLESS OTHERWISE SPECIFIED			CHECKED	19-2-91
			APPROVED	30-12-93
			SCALE	2:1
PARTY'S NAME	MADHUR RACKS & SYSTEMS PVT. LTD., BANGALORE		WEIGHT kg/m	1.594
PARTY'S DRAWING No.	8999		SECTION No.	7604 25732
ALLOY & TEMPER	HE9 WP	LENGTH: 3658mm	DRAWING No.	
DESCRIPTION	HORIZONTAL SECTION-H		7604 25732	