

S420

7644

25745

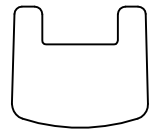

SCALE 1:1

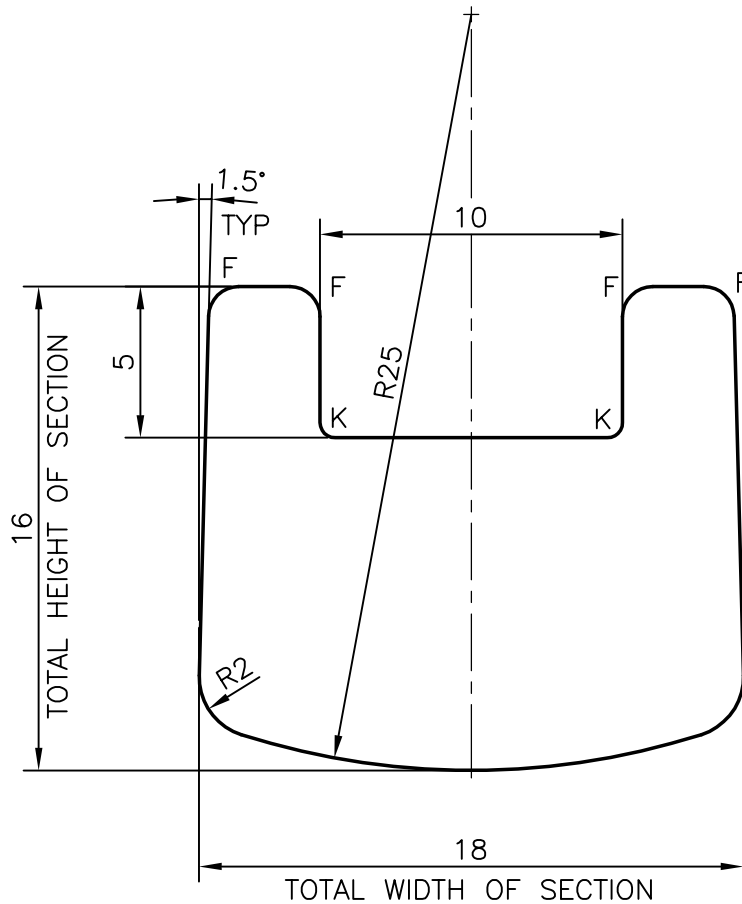

F = RADII 1.00 (4 PLACES)
K = RADII 0.50 (2 PLACES)



JINDAL ALUMINIUM LTD.
BANGALORE-560073 (INDIA)

	NAME	DATE
DRAWN	RAGHAVENDRA	16-12-2008
CHECKED		
APPROVED		

1. ALL DIMENSIONS ARE IN mm.
2. ROUND OFF ALL SHARP CORNERS WITH 0.40 mm.
3. TOLERANCES WILL BE AS PER IS:3965-1981 UNLESS OTHERWISE SPECIFIED

SCALE	4:1
AREA mm ²	222.256
PERIMETER mm.	71.566
WEIGHT kg/m	0.600

PARTY'S NAME	BHARAT ELECTRONICS LIMITED., BANGALORE
PARTY'S DRAWING No.	5161 127 001 42 A4
ALLOY & TEMPER	HE30 WP
DESCRIPTION	ELECTRONICS SECTION

DRAWING No.	SECTION No.
S420	-
7644	7644
25745	25745