

P-5391
S1453
25760

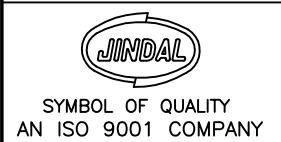
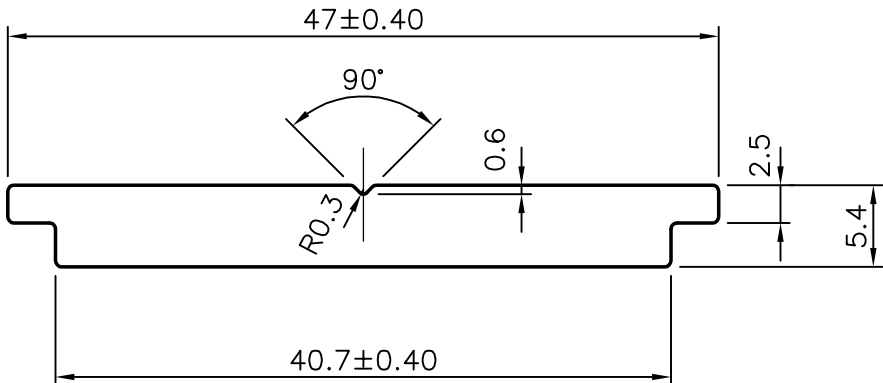
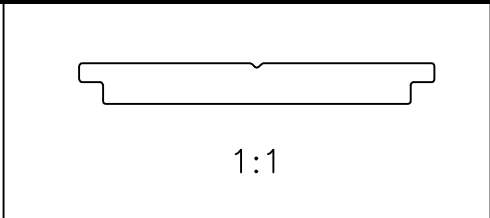

JINDAL ALUMINIUM LTD.
BANGALORE-560073 (INDIA)

	NAME	DATE
DRAWN	MALINGAPPA	29-03-2005
CHECKED		
APPROVED		

1. ALL DIMENSIONS ARE IN mm.
2. ROUND OFF ALL SHARP CORNERS WITH 0.40 mm.
3. TOLERANCES WILL BE AS PER IS: 3965-1981 UNLESS OTHERWISE SPECIFIED

SCALE	2:1
AREA mm ²	234.881
PERIMETER mm.	103.86
WEIGHT kg/m	0.634

PARTY'S NAME	DATTA ELECTRO-MECHANICAL DEVICES, BANGALORE
PARTY'S DRAWING No.	AS PER DRAWING (7592)
ALLOY & TEMPER	HE30 WP
DESCRIPTION	EXTRUSION FOR SWIVEL SLIDE

DRAWING No.	SECTION No.
P-5391	-
S1453	S1453
25760	25760