

P-8955

25773

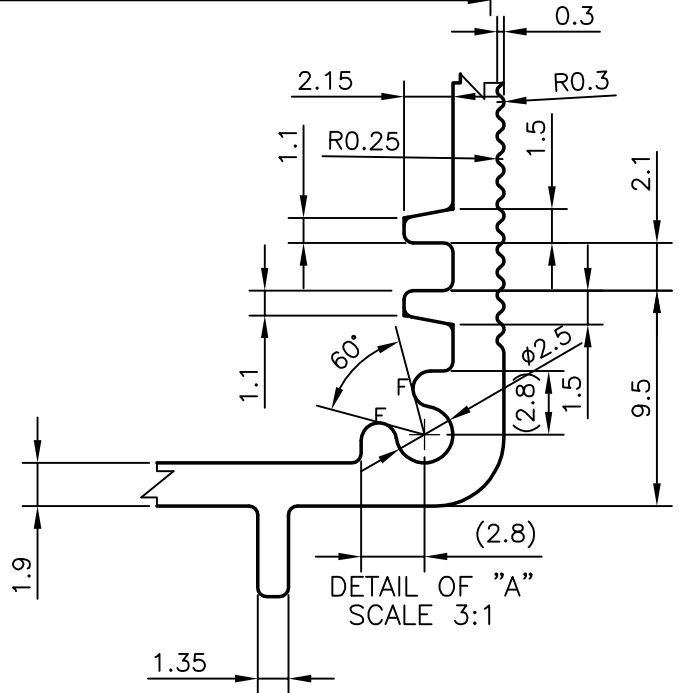

F = FULL RADIUS (8 PLACE)

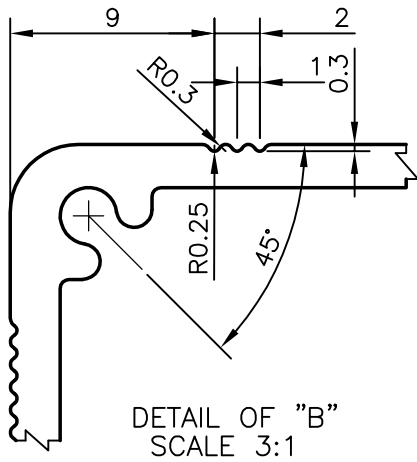
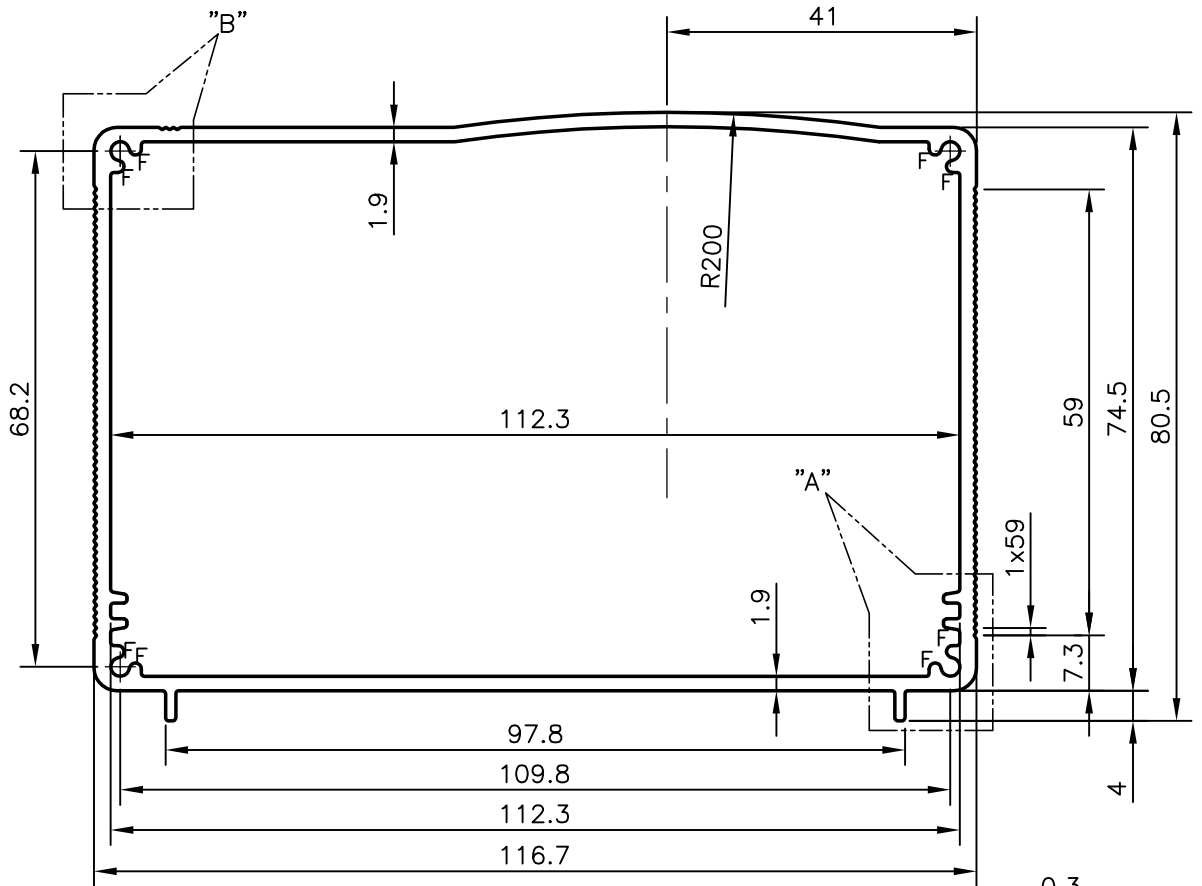

SYMBOL OF QUALITY  
AN ISO 9001 COMPANY

**JINDAL ALUMINIUM LTD.**  
BANGALORE-560073 (INDIA)

	NAME	DATE
DRAWN	J.P.KAUSHIK	01-01-2009
CHECKED		
APPROVED		

1. ALL DIMENSIONS ARE IN mm.
2. ROUND OFF ALL SHARP CORNERS WITH 0.40 mm.
3. TOLERANCES WILL BE AS PER IS:6477-1983 UNLESS OTHERWISE SPECIFIED

SCALE	1:1
AREA mm <sup>2</sup>	775.508
PERIMETER mm.	419.096
WEIGHT kg/m	2.094

PARTY'S NAME	UNIFIED ELECTRONICS (INDIA) LTD., BANGALORE
PARTY'S DRAWING No.	AS PER SAMPLE
ALLOY & TEMPER	HE9 WP
DESCRIPTION	ELECTRONICS SECTION

DRAWING No.	SECTION No.
P-8955	-
25773	25773