

P-9987-2

S2536

25780

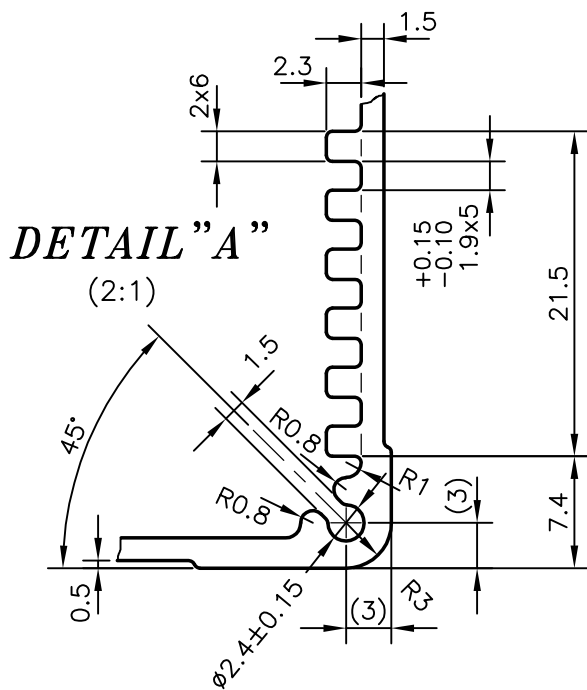
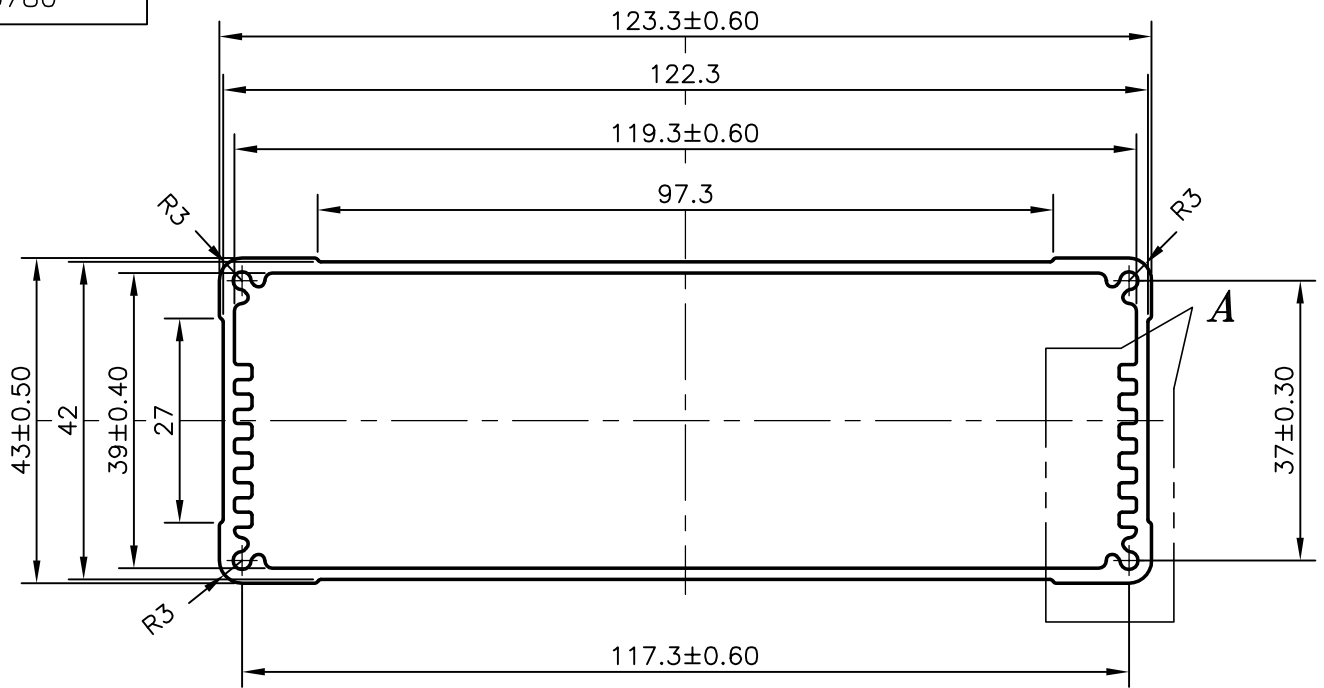

SYMBOL OF QUALITY  
AN ISO 9001 COMPANY

**JINDAL ALUMINIUM LTD.**  
BANGALORE-560073 (INDIA)

	NAME	DATE
DRAWN	J.P.KAUSHIK	12-05-2010
CHECKED		
APPROVED	S.S.GARG	21-05-2010
SCALE		1:1
AREA mm <sup>2</sup>		597.246
PERIMETER mm.		329.11
WEIGHT kg/m		1.613
DRAWING No.	SECTION No.	
P-9987-2	-	
S2536	S2536	
25780	25780	

1. ALL DIMENSIONS ARE IN mm.
2. ROUND OFF ALL SHARP CORNERS WITH 0.40 mm.
3. TOLERANCES WILL BE AS PER IS:6477-1983 UNLESS OTHERWISE SPECIFIED

PARTY'S NAME: EASUN REYROLLE LTD., HOSUR

PARTY'S DRAWING No.: 8873B96114

ALLOY & TEMPER: HE9 WP

DESCRIPTION: ELECTRONICS SECTION