

P-9513

S2300

25788

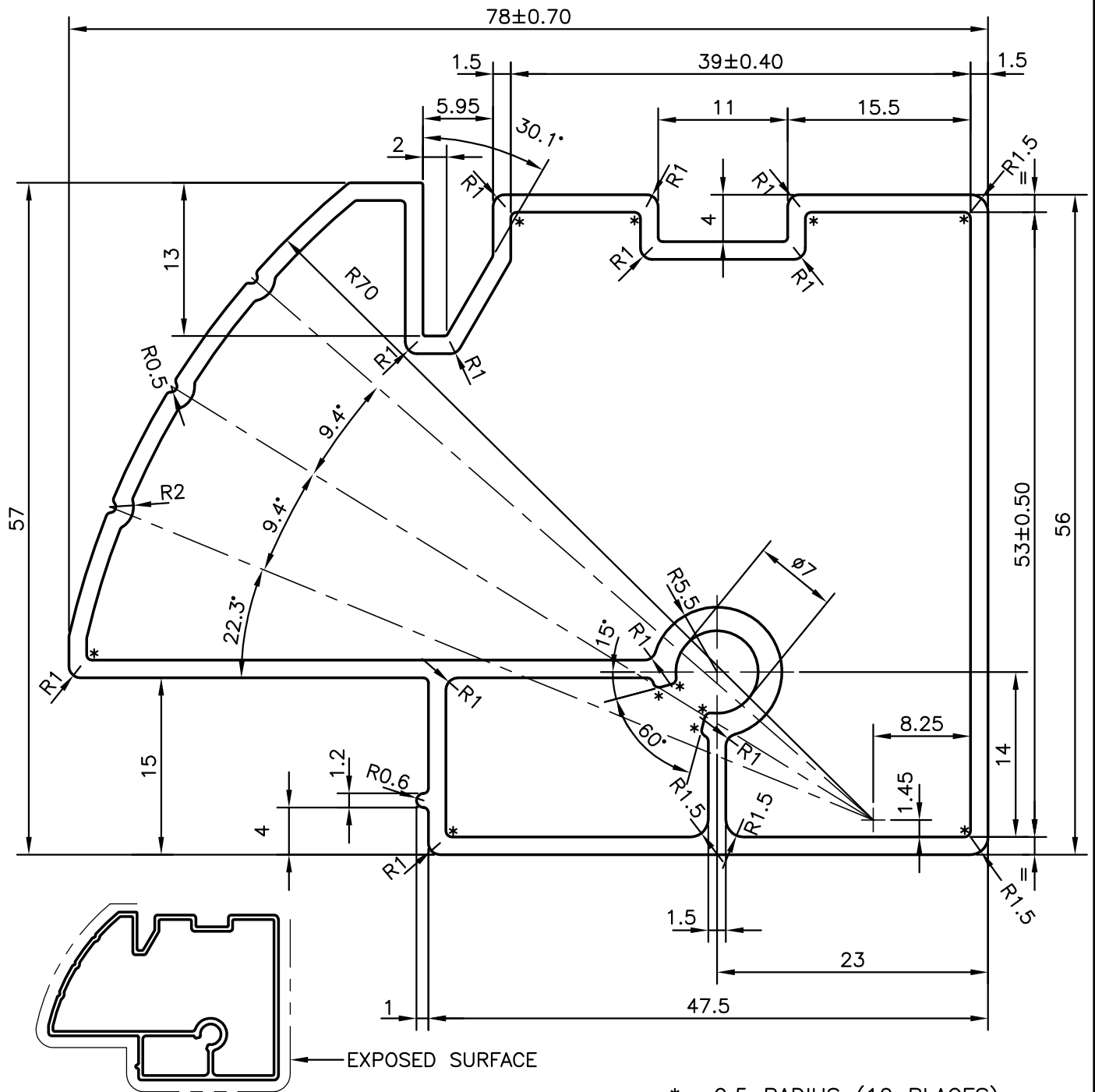

* = 0.5 RADIUS (10 PLACES)
GENERAL WALL THICKNESS 1.5 mm



SYMBOL OF QUALITY
AN ISO 9001 COMPANY

JINDAL ALUMINIUM LTD.
BANGALORE-560073 (INDIA)

	NAME	DATE
DRAWN	J.P.KAUSHIK	03-10-2009
CHECKED		
APPROVED		

- ALL DIMENSIONS ARE IN mm.
- ROUND OFF ALL SHARP CORNERS WITH 0.40 mm.
- TOLERANCES WILL BE AS PER IS:6477-1983 UNLESS OTHERWISE SPECIFIED

SCALE	2:1
AREA mm ²	503.29
PERIMETER mm.	280.996
WEIGHT kg/m	1.359

PARTY'S NAME	DEURO ELECTRONIC SYSTEMS PVT.LTD.,MUMBAI
PARTY'S DRAWING No.	24002036
ALLOY & TEMPER	6063 T6
DESCRIPTION	FRONT/REAR HORIZONTAL PROFILE LOGIC-2

DRAWING No.	SECTION No.
P-9513	-
S2300	S2300
25788	25788