

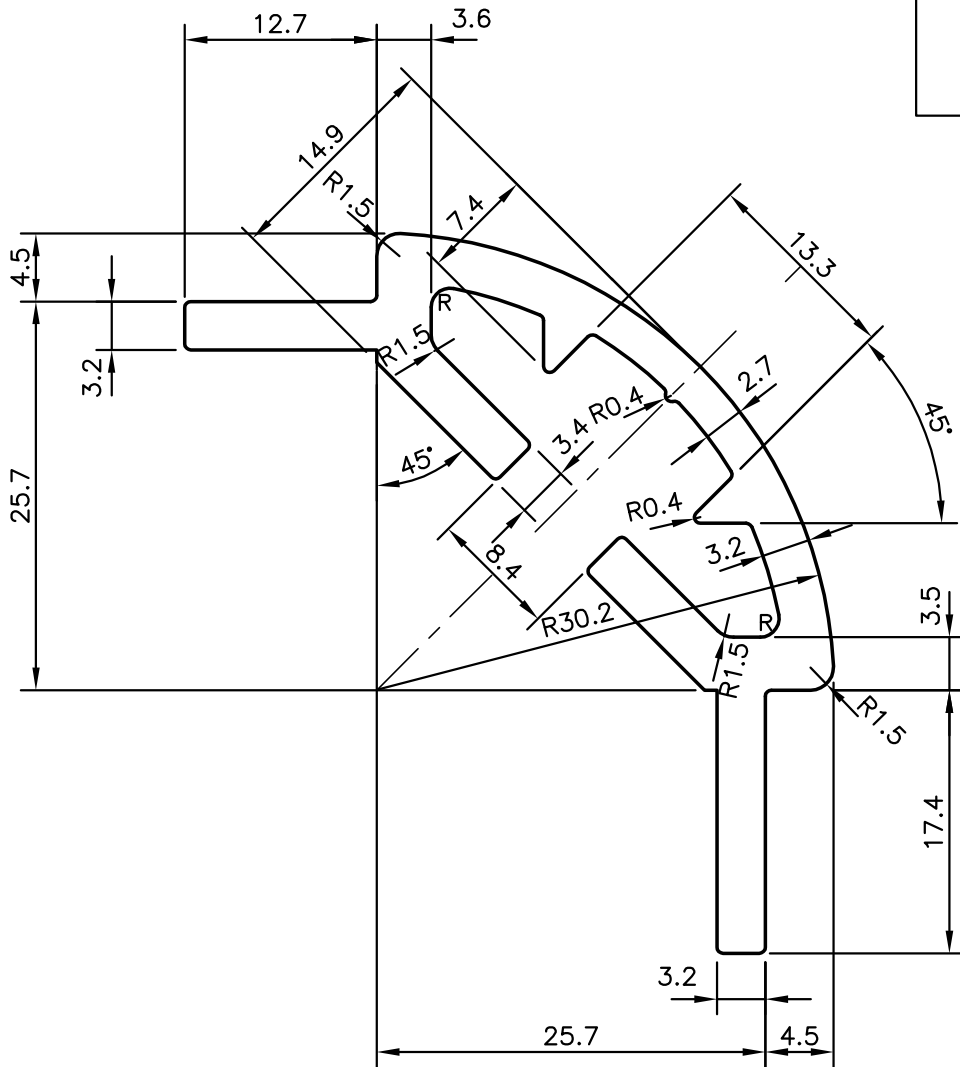

P-10168-2
S2640
25795

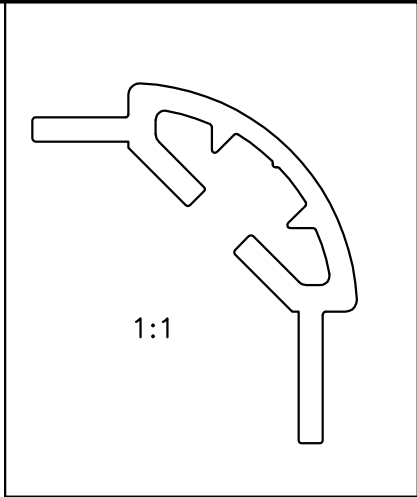

R = 1.25 RADIUS (2 PLACES)

 SYMBOL OF QUALITY AN ISO 9001 COMPANY	<b>JINDAL ALUMINIUM LTD.</b> BANGALORE-560073 (INDIA)	NAME		DATE
		DRAWN	J.P.KAUSHIK	16-07-2010
1. ALL DIMENSIONS ARE IN mm. 2. ROUND OFF ALL SHARP CORNERS WITH 0.40 mm. 3. TOLERANCES WILL BE AS PER BS:EN-12020-2 UNLESS OTHERWISE SPECIFIED		CHECKED		
		APPROVED		S.S.GARG
PARTY'S NAME		SCALE		2:1
		AREA mm <sup>2</sup>		348.722
PARTY'S DRAWING No.		PERIMETER mm.		220.412
		WEIGHT kg/m		0.942
ALLOY & TEMPER		DRAWING No.		SECTION No.
		P-10168-2		-
DESCRIPTION		S2640		S2640
		25795		25795