

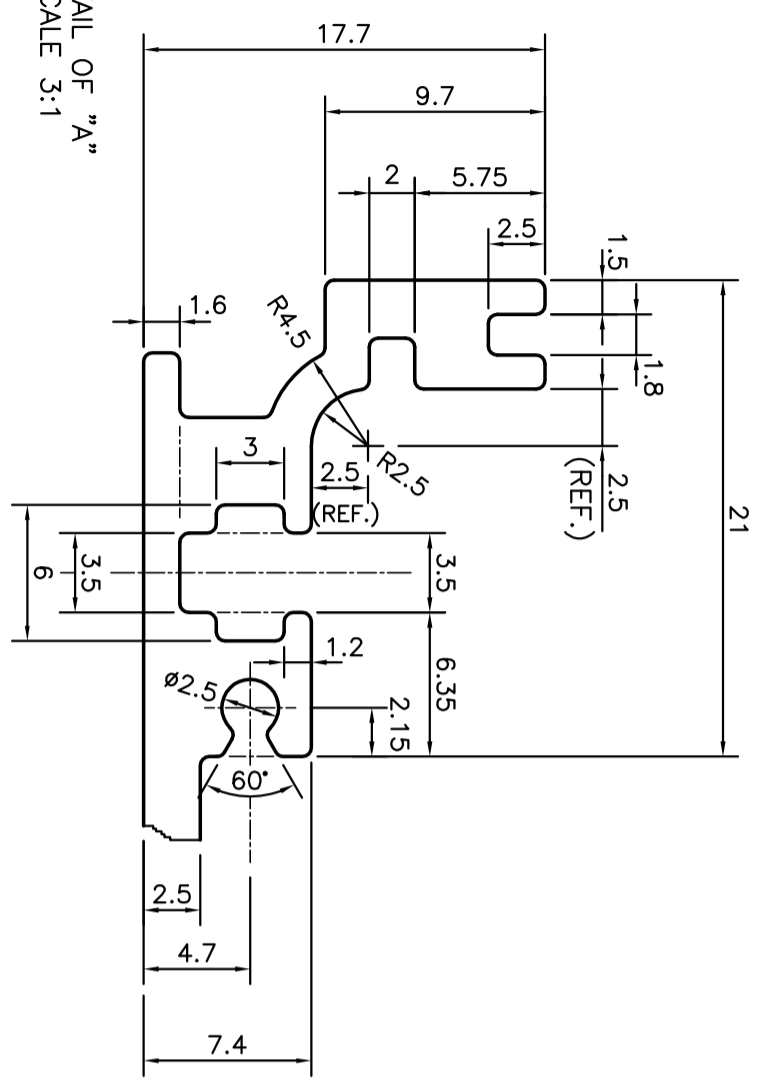

P-10868
S2888
25800

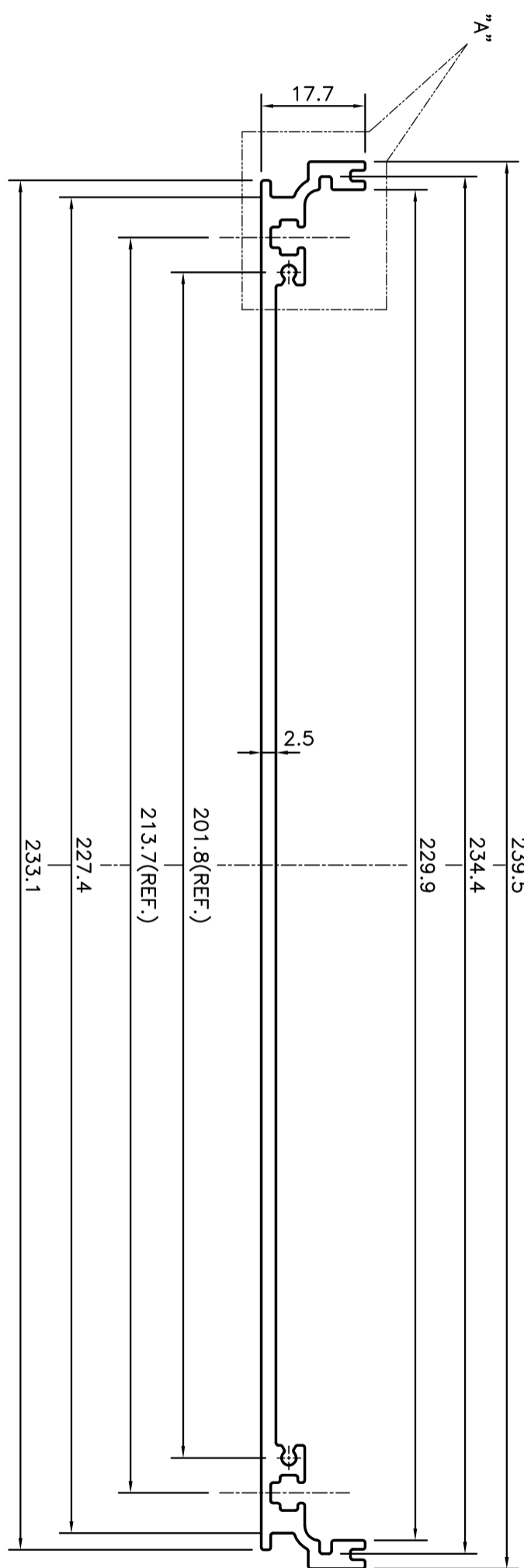

DETAIL OF "A"  
SCALE 3:1

 SYMBOL OF QUALITY AN ISO 9001 COMPANY	<b>JINDAL ALUMINIUM LTD.</b> BANGALORE-560073 (INDIA)	DRAWN	J.P. KAUSHIK	DATE	25-03-2011
		CHECKED			
1. ALL DIMENSIONS ARE IN mm. 2. ROUND OFF ALL SHARP CORNERS WITH 0.40 mm. 3. TOLERANCES WILL BE AS PER BS:EN-755-9 UNLESS OTHERWISE SPECIFIED		APPROVED	S.S.GARG		01-04-2011
PARTY'S NAME	M. P. INDUSTRIES, MUMBAI	SCALE	1:1		
PARTY'S DRAWING No.	SHYN162005	AREA mm <sup>2</sup>	739.853		
ALLOY & TEMPER	HE9 WP	PERIMETER mm.	605.973		
DESCRIPTION	MISC. SECTION	WEIGHT kg/m	1.998		
		DRAWING No.	SECTION No.		
		P-10868	-		
		S2888	S2888		
		25800	25800		