

P-14669-2

S4481

25820

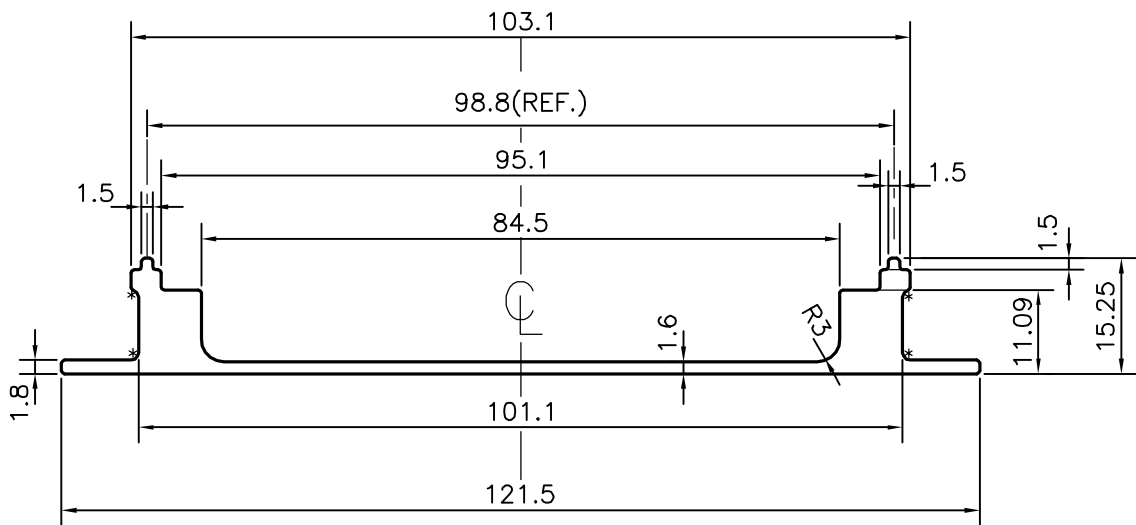
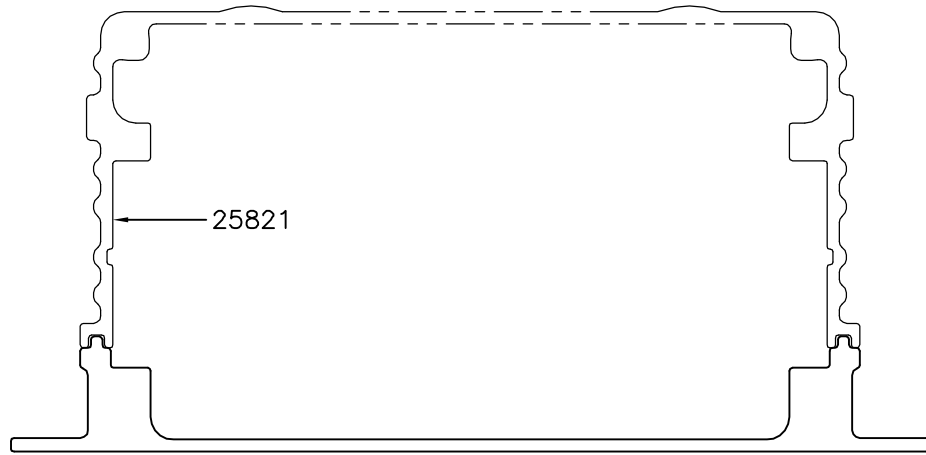

* = RADIUS 1.0 (4 PLACES)



SYMBOL OF QUALITY
AN ISO 9001 COMPANY

JINDAL ALUMINIUM LTD.
BANGALORE-560073 (INDIA)

	NAME	DATE
DRAWN	J.P.KAUSHIK	30-05-2015
CHECKED		
APPROVED	S.S.GARG	03-06-2015
SCALE		1:1
AREA mm ²		386.199
PERIMETER mm.		296.836
WEIGHT kg/m		1.043
DRAWING No.	SECTION No.	
P-14669-2	-	
S4481	S4481	
25820	25820	

1. ALL DIMENSIONS ARE IN mm.
2. ROUND OFF ALL SHARP CORNERS WITH 0.40 mm.
3. TOLERANCES WILL BE AS PER,IS:3965-1981 UNLESS OTHERWISE SPECIFIED

PARTY'S NAME	GENSER AEROSPACE & INFORMATION TECHNOLOGIES PVT. LTD., BANGALORE
PARTY'S DRAWING No.	AS PER AutoCAD DRAWING(9001881-001)
ALLOY & TEMPER	6063 T6
DESCRIPTION	BOTTOM PROFILE