

P-14670-2

S4482

25821

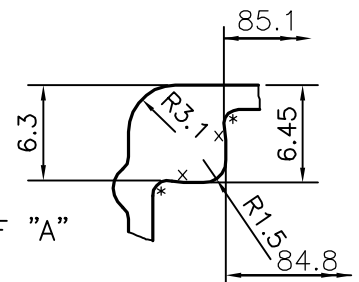
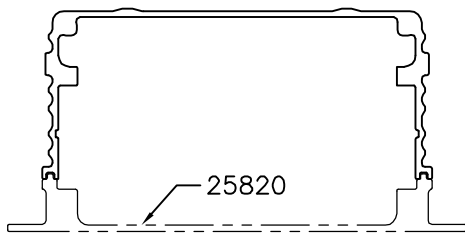
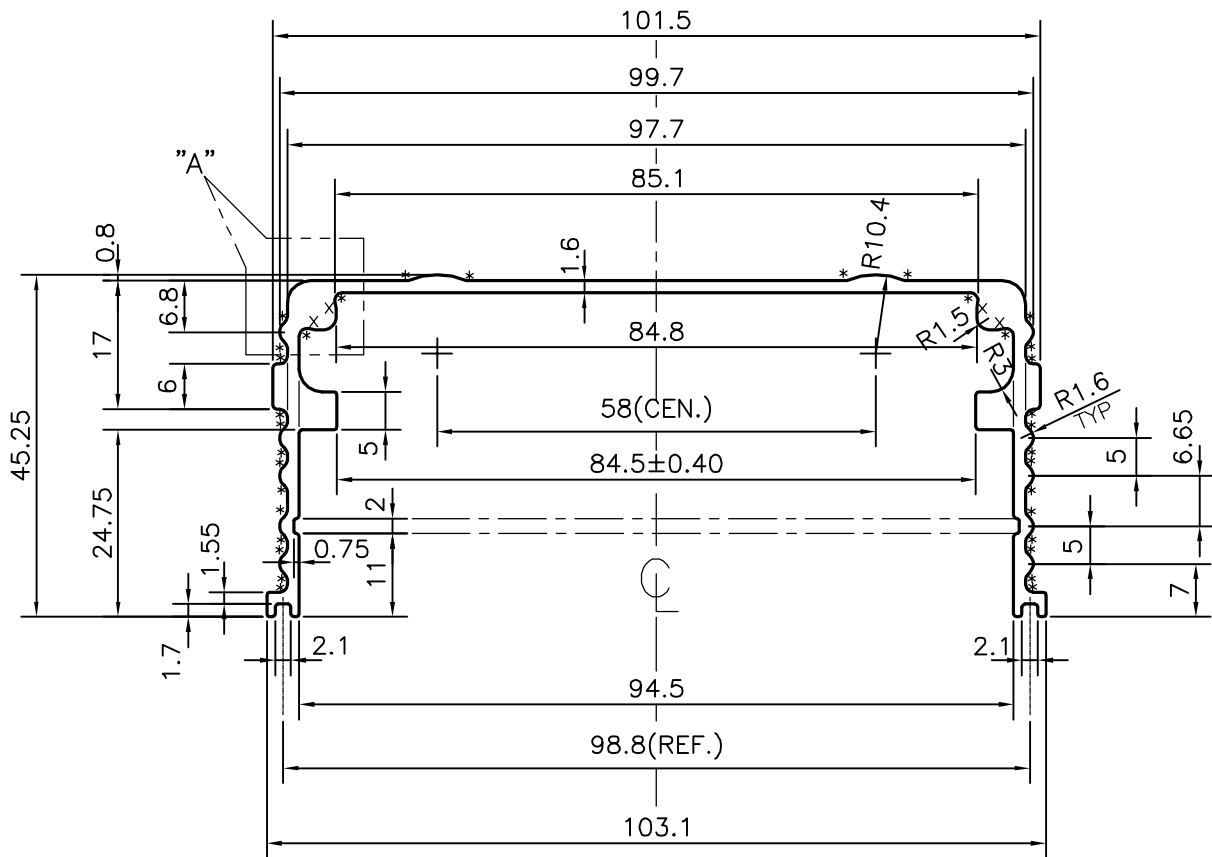

DETAILS OF "A"
SCALE 3:1

x = RADIUS 2.75 (4 PLACES)

* = RADIUS 1.0 (34 PLACES)



SYMBOL OF QUALITY
AN ISO 9001 COMPANY

JINDAL ALUMINIUM LTD.
BANGALORE-560073 (INDIA)

	NAME	DATE
DRAWN	J.P.KAUSHIK	30-05-2015
CHECKED		
APPROVED	S.S.GARG	03-06-2015

1. ALL DIMENSIONS ARE IN mm.
2. ROUND OFF ALL SHARP CORNERS WITH 0.40 mm.
3. TOLERANCES WILL BE AS PER, IS:3965-1981 UNLESS OTHERWISE SPECIFIED

SCALE	1:1
AREA mm ²	451.171
PERIMETER mm.	409.175
WEIGHT kg/m	1.218

PARTY'S NAME	GENSER AEROSPACE & INFORMATION TECHNOLOGIES PVT. LTD., BANGALORE
PARTY'S DRAWING No.	AS PER AutoCAD DRAWING(9001879-001)
ALLOY & TEMPER	6063 T6
DESCRIPTION	TOP PROFILE

DRAWING No.	SECTION No.
P-14670-2	-
S4482	S4482
25821	25821