

S610
7967
26217

DETAIL A
SCALE 5:1

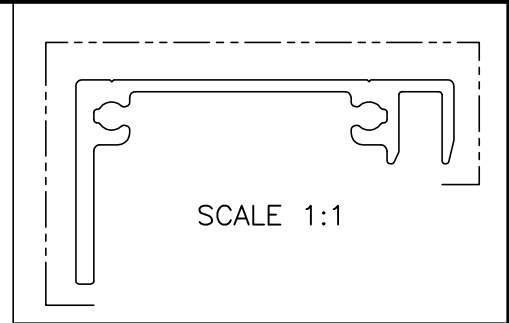
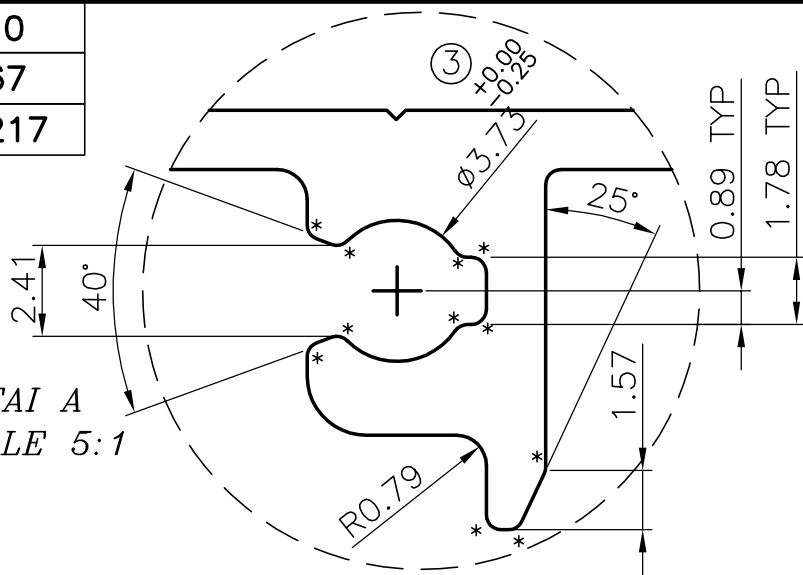

NOTE:

1. PARTS TO BE FREE OF BURRS, STEPS, GROOVES, ETC.
2. AREA TO BE FREE OF SCRATCHES.
3. *=RADII 0.40 (26-PLCS)

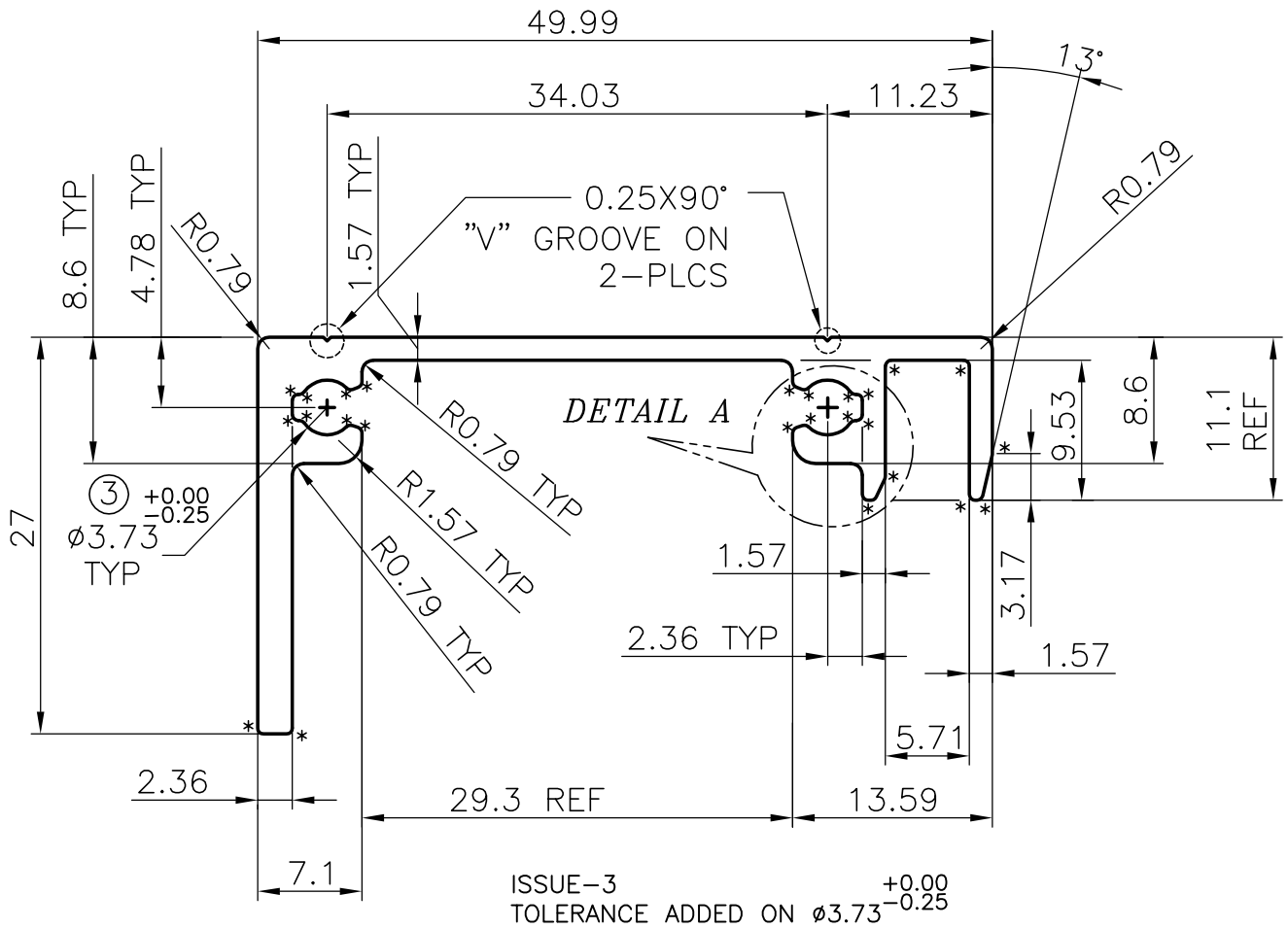

ISSUE-2
TOLERANCE CHANGED FROM IS:3965-1981
TO DIN EN12020-2 (27/05/2009) ----- EXPOSED SURFACE REQUIRED BETTER FINISH

 SYMBOL OF QUALITY AN ISO 9001 COMPANY	JINDAL ALUMINIUM LTD. BANGALORE-560073 (INDIA)	NAME	DATE	
		DRAWN	J.P.KAUSHIK 25-06-2010	
		CHECKED		
APPROVED				
1. ALL DIMENSIONS ARE IN mm. 2. ROUND OFF ALL SHARP CORNERS WITH 0.80 mm. 3. TOLERANCES WILL BE AS PER EN:12020-2 UNLESS OTHERWISE SPECIFIED		SCALE	2:1	
		AREA mm ²	204.018	
		PERIMETER mm.	203.731	
PARTY'S NAME		TATA BP SOLAR INDIA LTD ELECTRONIC CITY	WEIGHT kg/m	0.552
PARTY'S DRAWING No.		AS PER DRAWING (D15120)	DRAWING No.	SECTION No.
ALLOY & TEMPER		6063-T6	S610	S610
DESCRIPTION		FRAME SIDE OPTIMIZED	7967	7967
			26217	26217-ISSUE-3