

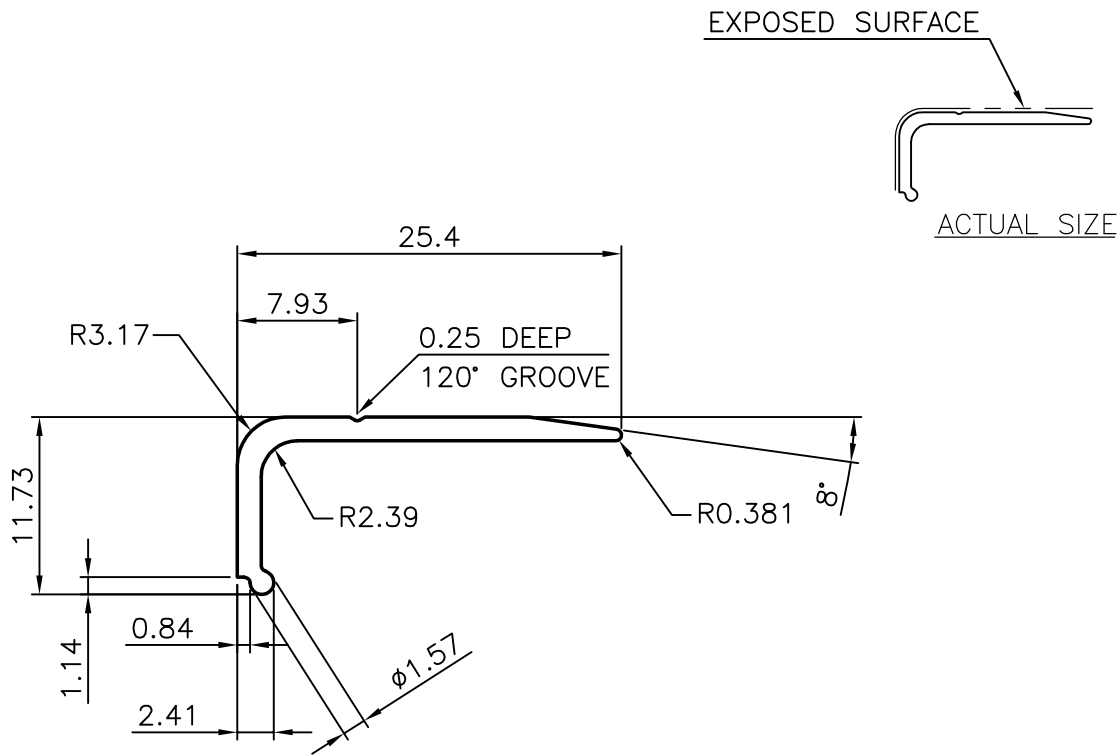

9016

26224



NOTE:-

UNLESS OTHERWISE SPECIFIED, WALL THICKNESS = 1.57.

 SYMBOL OF QUALITY AN ISO 9002 COMPANY	JINDAL ALUMINIUM LTD. BANGALORE-560073 (INDIA)		NAME	DATE
			DRAWN	PRASAD
1. ALL DIMENSIONS ARE IN mm. 2. ROUND OFF SHARP CORNERS WITH 0.4mm. R. 3. TOLERANCES ARE AS PER I.S. 3965-1981.			CHECKED	
			APPROVED	
			SCALE	2:1
PARTY'S NAME	BEST & CROMPTON ENGG. CO. LTD., MADRAS		WEIGHT kg/m	0.141
PARTY'S DRAWING No.	814369	FINISH	AS EXTRUDED	SECTION No. 26224 26224
ALLOY & TEMPER	HE 9 WP	LENGTH:	3385 ⁺⁵ / ₋₀ mm	DRAWING No. 26224 26224
DESCRIPTION	BATTEN			