

9017

26225

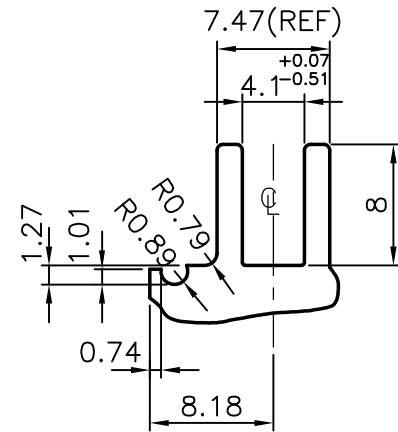

DETAIL-A

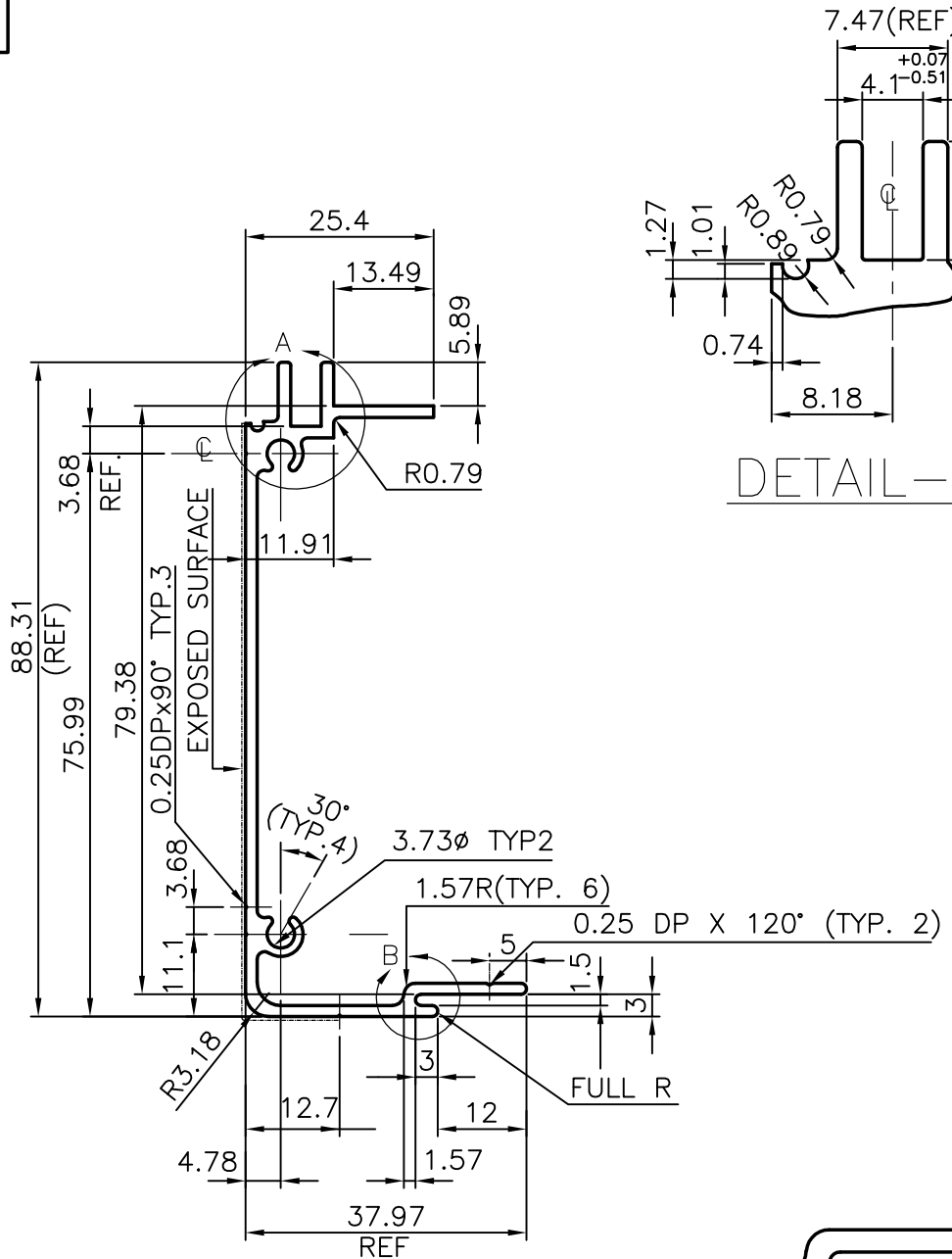
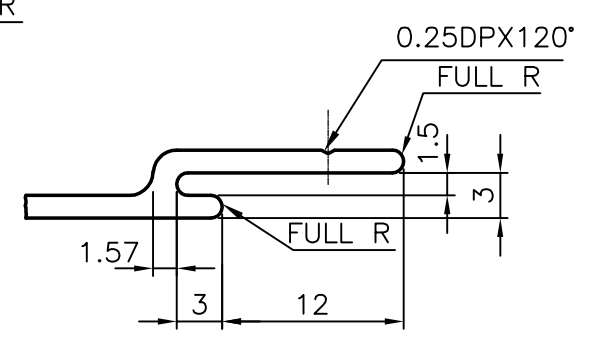

DETAIL-B

UNSPECIFIED WALL THICKNESS = 1.57 mm

 SYMBOL OF QUALITY AN ISO 9002 COMPANY	JINDAL ALUMINIUM LTD. BANGALORE-560073 (INDIA)		NAME	DATE
			DRAWN	S.KUMAR
1. ALL DIMENSIONS ARE IN mm. 2. ROUND OFF ALL SHARP CORNERS WITH 0.40 mm. 3. TOLERANCES WILL BE AS PER IS: 3965-1981, UNLESS OTHERWISE SPECIFIED			CHECKED	
			APPROVED	
			SCALE	1:1
PARTY'S NAME	BEST & CROMPTON ENGG. LTD. (MADRAS)		WEIGHT kg/m	0.829
PARTY'S DRAWING No.	814368 (REVISED)		SECTION No.	XXX 26225
ALLOY & TEMPER	HE 9 WP	LENGTH: 3385 ⁺⁵ / ₋₀ mm.	DRAWING No.	
DESCRIPTION	COLLECTOR FRAME		XXX 26225	