

P-7345

26245

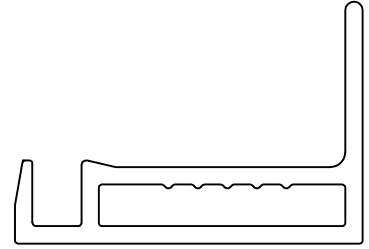

1:1

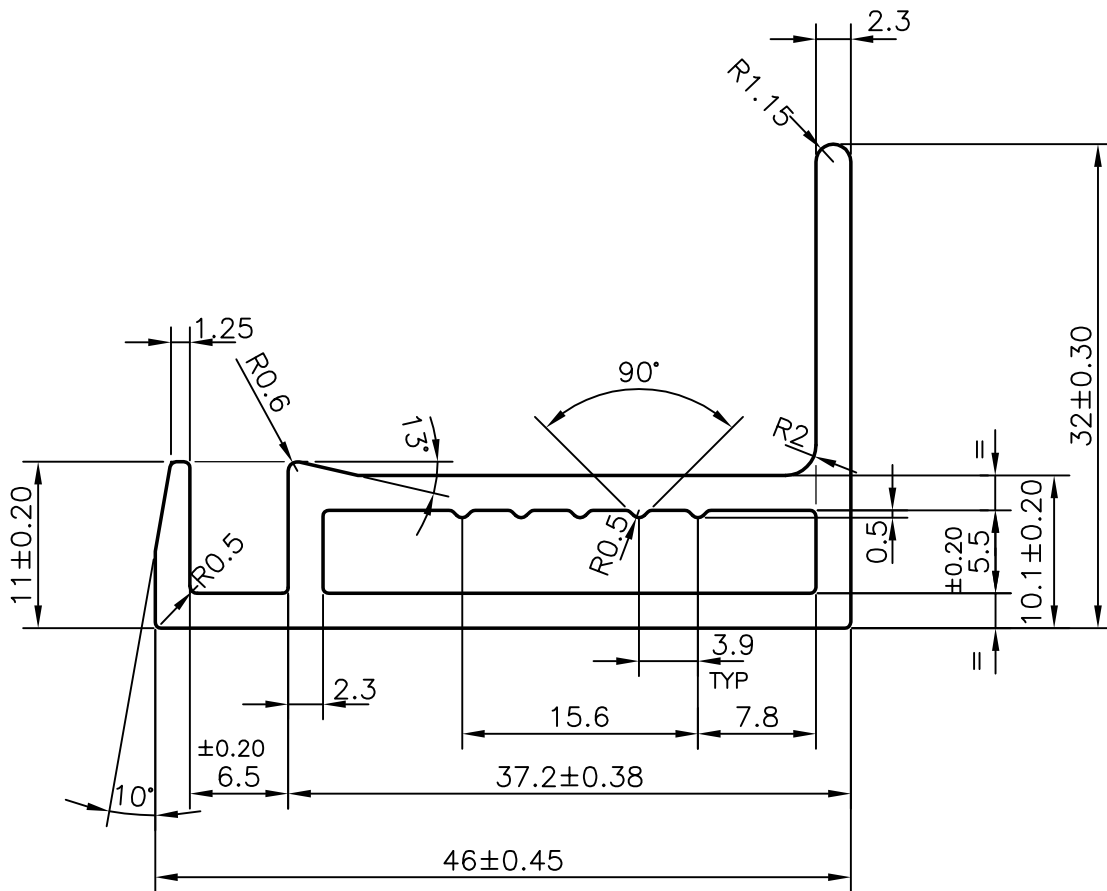

SYMBOL OF QUALITY
AN ISO 9002 COMPANY

JINDAL ALUMINIUM LTD.
BANGALORE-560073 (INDIA)

	NAME	DATE
DRAWN	J.P.KAUSHIK	09-06-2007
CHECKED		
APPROVED		
SCALE		2:1
AREA mm ²		288.788
PERIMETER mm.		170.326
WEIGHT kg/m		0.78

1. ALL DIMENSIONS ARE IN mm.
2. ROUND OFF ALL SHARP CORNERS WITH 0.40 mm.
3. TOLERANCES WILL BE AS PER IS:6477-1983 UNLESS OTHERWISE SPECIFIED

PARTY'S NAME GENERAL CATEGORY, BANGALORE MARKET

PARTY'S DRAWING No. AS PER DRAWING

ALLOY & TEMPER HE9 WP

DESCRIPTION SOLAR SECTION

DRAWING No.	SECTION No.
P-7345	-
26245	26245