

P-10300

S2679

26270

SCALE 1:1

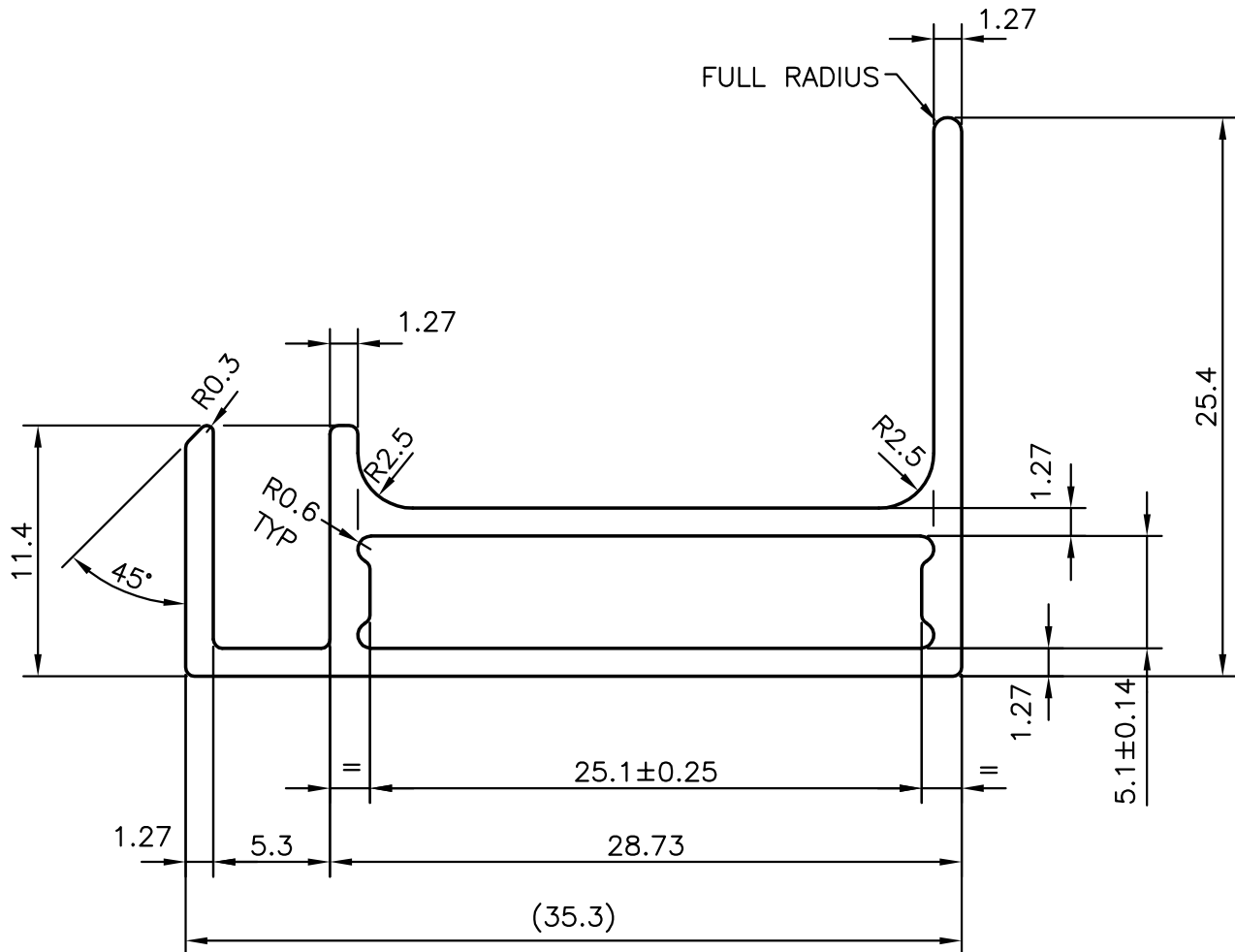
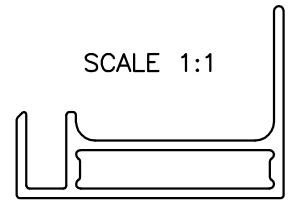

TOLERANCE ON THICKNESS $1.27^{+0.25}_{-0.10}$ FOR INTERNAL USE (EXTRUSION, DIMENSION)
(SIZES KEPT ON PLUS SIDE FOR ANODIZING)



SYMBOL OF QUALITY
AN ISO 9001 COMPANY

JINDAL ALUMINIUM LTD.
BANGALORE-560073 (INDIA)

	NAME	DATE
DRAWN	J.P.KAUSHIK	11-08-2010
CHECKED		
APPROVED	S.S.GARG	17-01-2012

1. ALL DIMENSIONS ARE IN mm.
2. ROUND OFF ALL SHARP CORNERS WITH 0.40 mm.
3. TOLERANCES WILL BE AS PER IS:6477-1983 UNLESS OTHERWISE SPECIFIED

SCALE	3:1
AREA mm ²	140.032
PERIMETER mm.	144.805
WEIGHT kg/m	0.378

PARTY'S NAME VIKRAM SOLAR PVT. LTD., KOLKATA

PARTY'S DRAWING No. VSPL/PRN/116/10

ALLOY & TEMPER 6063 T6

DESCRIPTION SOLAR SECTION-PV FRAME 3.2mm. GLASS

DRAWING No.	SECTION No.
P-10300	-
S2679	S2679
26270	26270