

P-10873-1

S2890

26275

SCALE 1:1

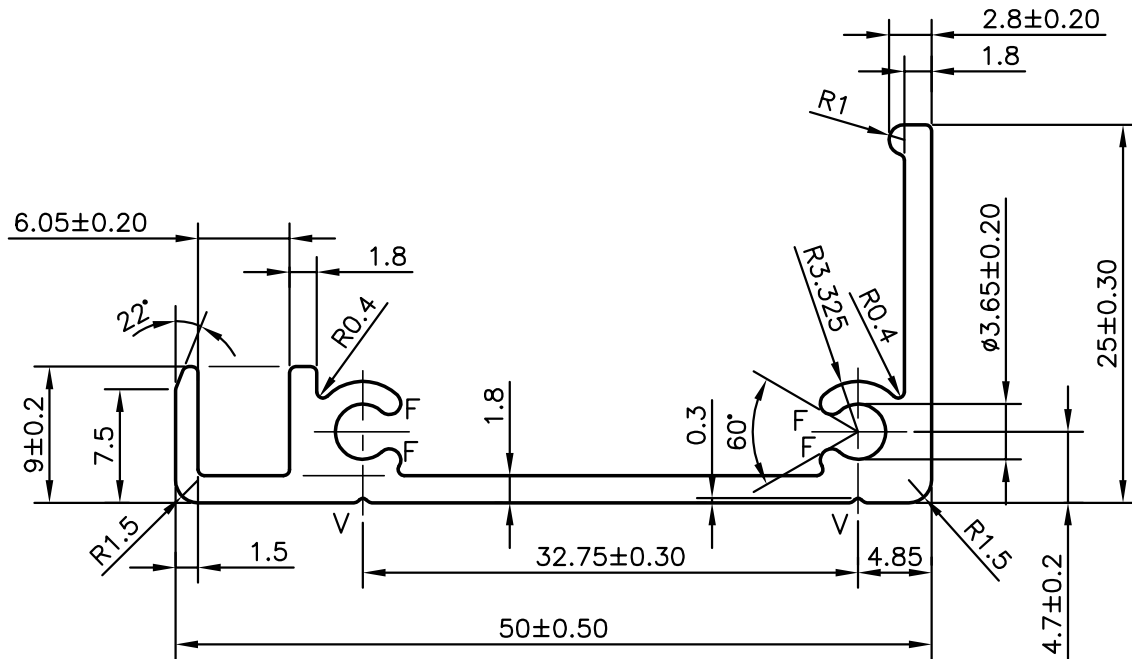
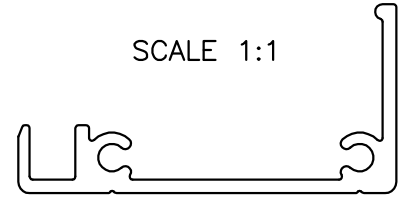

V = VEE GROOVE (0.3x90°) (2 PLACES)



SYMBOL OF QUALITY  
AN ISO 9001 COMPANY

**JINDAL ALUMINIUM LTD.**  
BANGALORE-560073 (INDIA)

	NAME	DATE
DRAWN	RAGHAVENDRA	09-04-2011
CHECKED		
APPROVED	S.S.GARG	12-04-2011

1. ALL DIMENSIONS ARE IN mm.
2. ROUND OFF ALL SHARP CORNERS WITH 0.40 mm.
3. TOLERANCES WILL BE AS PER IS:3965-1981 UNLESS OTHERWISE SPECIFIED

SCALE	2:1
AREA mm <sup>2</sup>	194.525
PERIMETER mm.	194.601
WEIGHT kg/m	0.525

PARTY'S NAME EMMVEE PHOTOVOLTAIC POWER PVT. LTD., BANGALORE

DRAWING No.	SECTION No.
P-10873-1	-
S2890	S2890
26275	26275

PARTY'S DRAWING No. MV-PV-E-008 (LENGTH SECTION)

ALLOY & TEMPER HE9 WP

DESCRIPTION SOLAR POWER SECTION