

P-11360-1

26280

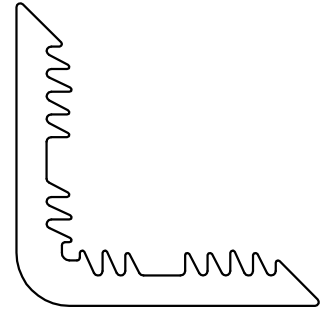

SCALE- 1:1

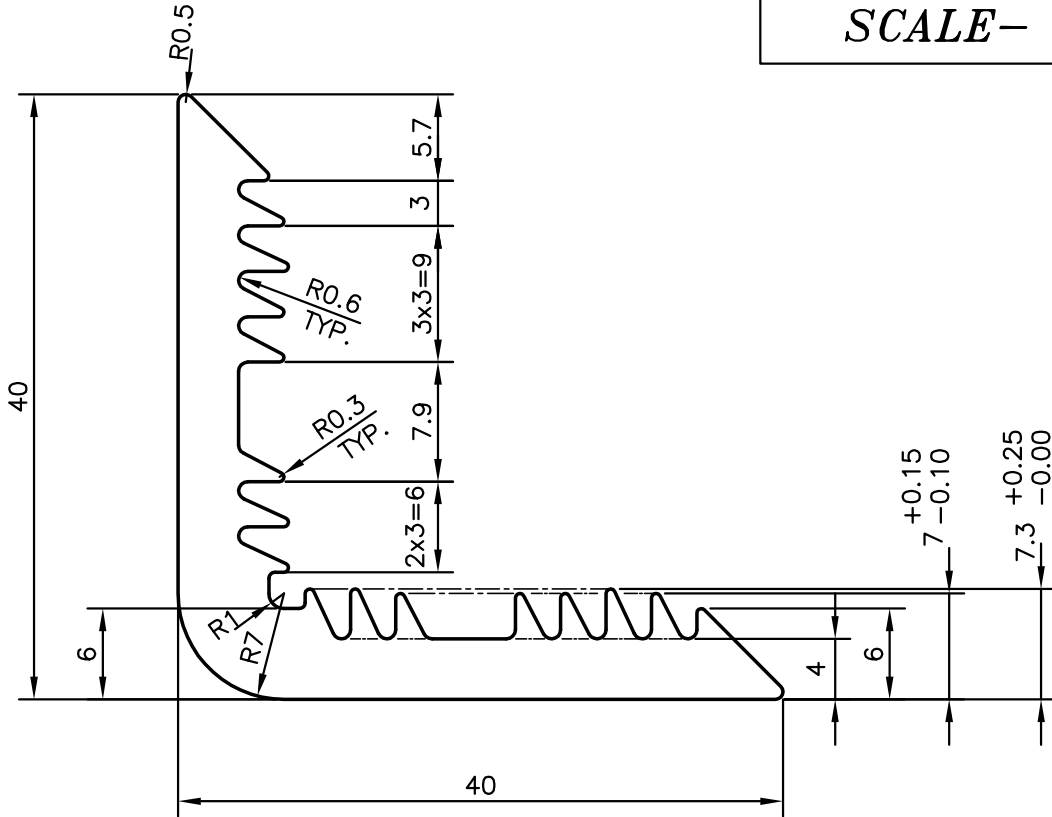

SYMBOL OF QUALITY
AN ISO 9001 COMPANY

JINDAL ALUMINIUM LTD.
BANGALORE-560073 (INDIA)

	NAME	DATE
DRAWN	PARVESH	06-12-2011
CHECKED		
APPROVED	S.S.GARG	10-12-2011
SCALE		2:1
AREA mm ²		358.181
PERIMETER mm.		213.284
WEIGHT kg/m		0.967

1. ALL DIMENSIONS ARE IN mm.
2. ROUND OFF ALL SHARP CORNERS WITH 0.40 mm.
3. TOLERANCES WILL BE AS PER BS:EN-12020-2, UNLESS OTHERWISE SPECIFIED

PARTY'S NAME	DINOR SOLAR, GMBH	DRAWING No.	P-11360-1	SECTION No.	-
PARTY'S DRAWING No.	F300-0000/0001		26280		26280
ALLOY & TEMPER	EN AW-6060 T66				
DESCRIPTION	SOLAR SECTION				