

P-10605

X1432

26286

SCALE 1:1

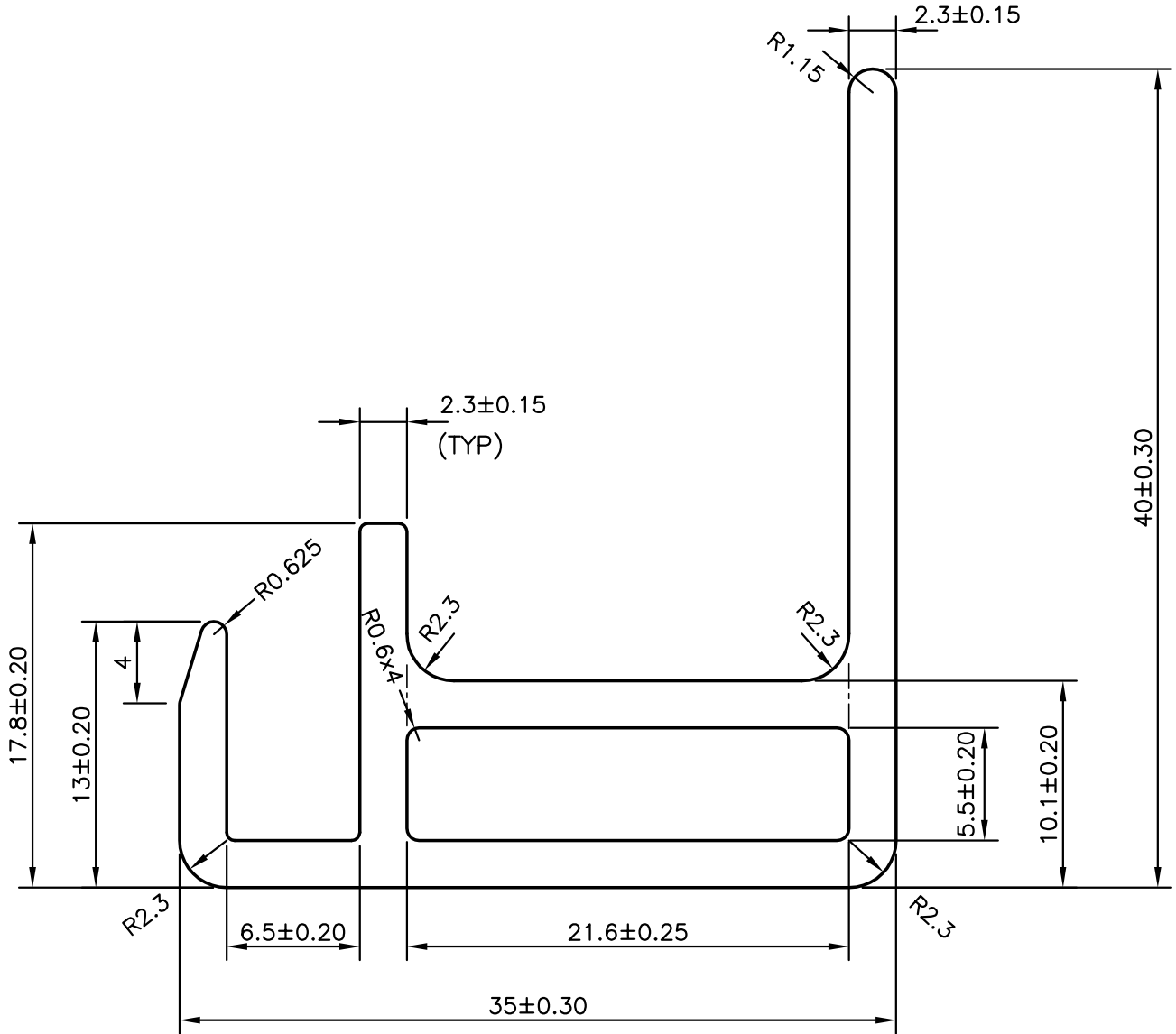
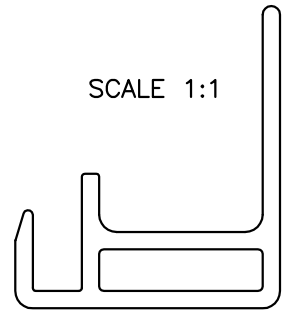

SYMBOL OF QUALITY  
AN ISO 9001 COMPANY

**JINDAL ALUMINIUM LTD.**  
BANGALORE-560073 (INDIA)

	NAME	DATE
DRAWN	J.P.KAUSHIK	01-12-2010
CHECKED		
APPROVED	J.N.RAI	06-12-2010

1. ALL DIMENSIONS ARE IN mm.
2. ROUND OFF ALL SHARP CORNERS WITH 0.40 mm.
3. TOLERANCES WILL BE AS PER IS:6477-1983 UNLESS OTHERWISE SPECIFIED

SCALE	3:1
AREA mm <sup>2</sup>	274.344
PERIMETER mm.	179.747
WEIGHT kg/m	0.741

PARTY'S NAME EMMVEE TOUGHENED GLASS AND PHOTOVOLTAICS PVT. LTD., BANGALORE

DRAWING No. SECTION No.

PARTY'S DRAWING No. MV-PV-F-000

P-10605 -

ALLOY & TEMPER HE9 WP

X1432 X1432

26286 26286

DESCRIPTION SOLAR PV MODULE 35 mm FRAME SECTION