

P-13971

26298

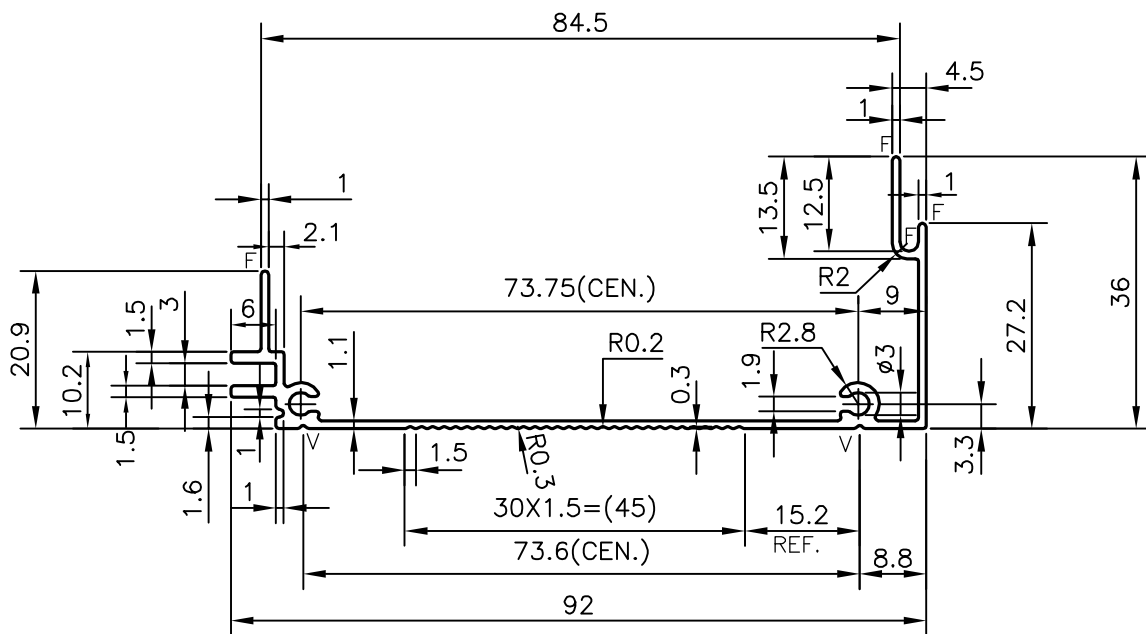

V = V GROOVE 0.5x90°(2 PLACES)
 F = FULL RADIUS(4 PLACES)



SYMBOL OF QUALITY
 AN ISO 9001 COMPANY

JINDAL ALUMINIUM LTD.
 BANGALORE-560073 (INDIA)

	NAME	DATE
DRAWN	J.P.KAUSHIK	06-09-2014
CHECKED		
APPROVED	S.S.GARG	02-07-2015
SCALE		1:1
AREA mm ²		192.521
PERIMETER mm.		345.168
WEIGHT kg/m		0.520
DRAWING No.	SECTION No.	
P-13971	-	
26298	26298	

1. ALL DIMENSIONS ARE IN mm.
2. ROUND OFF ALL SHARP CORNERS WITH 0.40 mm.
3. TOLERANCES WILL BE AS PER IS:3965-1981 , UNLESS OTHERWISE SPECIFIED

PARTY'S NAME	GENERAL CATEGORY,BANGALORE MARKET
PARTY'S DRAWING No.	AS PER SAMPLE & REQUIREMENT
ALLOY & TEMPER	HE9 WP
DESCRIPTION	SOLAR SECTION