

P-15208

S4706

26300

1:1

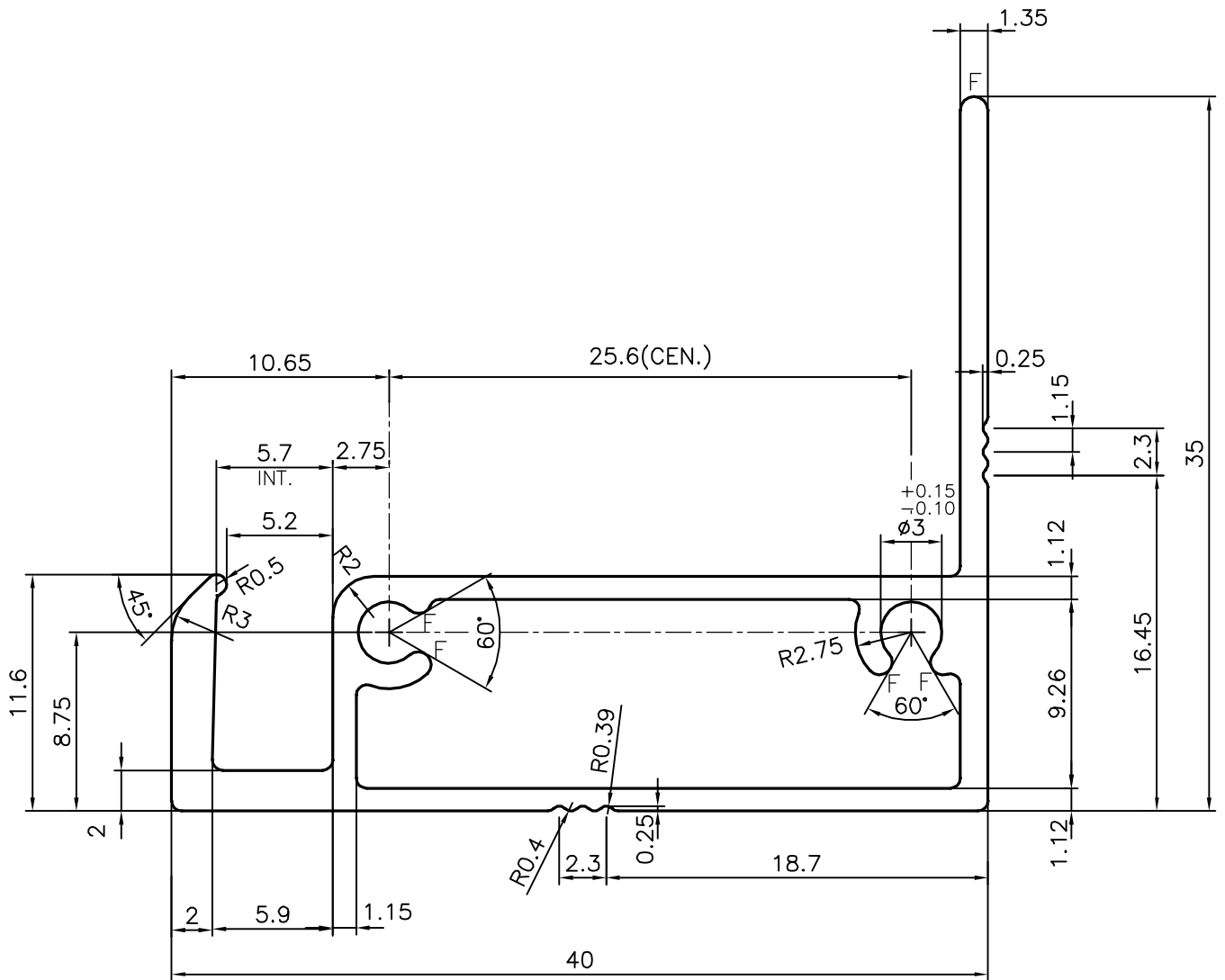
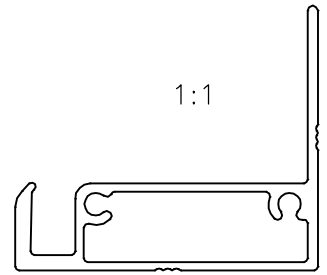

UNSPECIFIED RADIUS :-0.5 mm

F= FULL RADIUS (5 PLACES)



SYMBOL OF QUALITY
AN ISO 9001 COMPANY

JINDAL ALUMINIUM LTD.
BANGALORE-560073 (INDIA)

	NAME	DATE
DRAWN	J.P.KAUSHIK	29-09-2015
CHECKED		
APPROVED	S.S.GARG	13-10-2015
SCALE		3:1
AREA mm ²		175.96
PERIMETER mm.		166.896
WEIGHT kg/m		0.475
DRAWING No.	SECTION No.	
P-15208	-	
S4706	S4706	
26300	26300	

1. ALL DIMENSIONS ARE IN mm. 2. ROUND OFF ALL SHARP CORNERS WITH 0.40 mm. 3. TOLERANCES WILL BE AS PER IS:6477-1983, UNLESS OTHERWISE SPECIFIED	
PARTY'S NAME	SHRI RAGHAVENDRA ENGG. WORKS, BANGALORE
PARTY'S DRAWING No.	AS PER AutoCAD DRAWING(TPS-D-148) EXTRUSION END
ALLOY & TEMPER	6063 T6
DESCRIPTION	SOLAR SECTION