

7594

26317

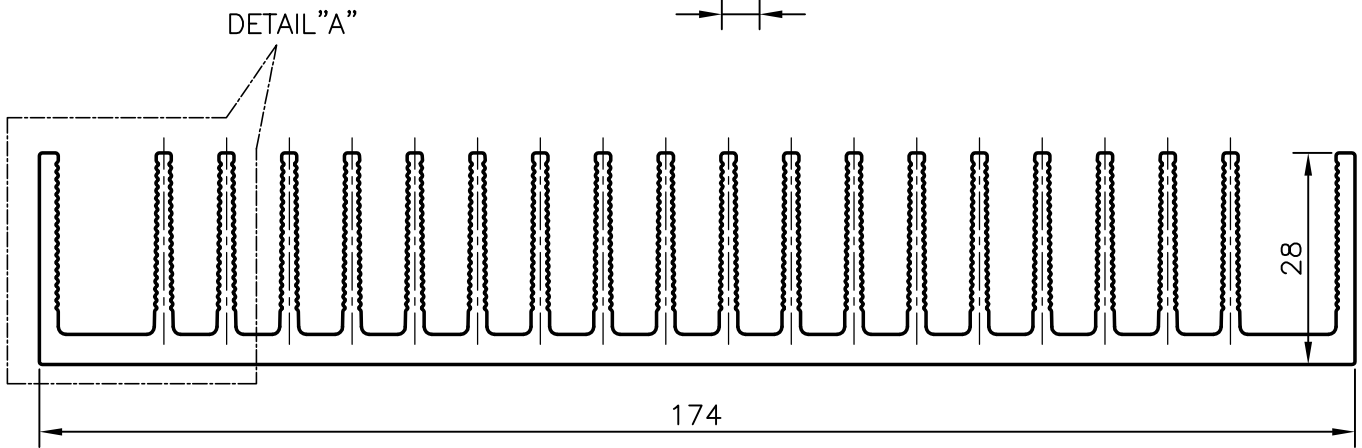

TOLERANCES ON DIMENSIONS, STRAIGHTNESS, FLATNESS, TWIST & ANGULARITY WILL BE AS PER IS:3965-1981

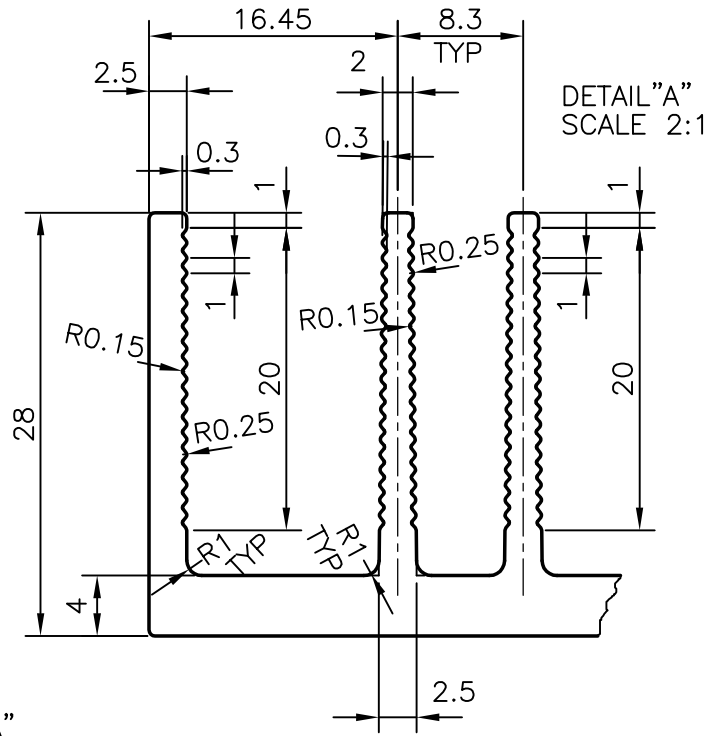

SYMBOL OF QUALITY  
AN ISO 9001 COMPANY

**JINDAL ALUMINIUM LTD.**  
BANGALORE-560073 (INDIA)

	NAME	DATE
DRAWN	RAGHAVENDRA	07-10-2009
CHECKED		
APPROVED		
SCALE		1:1
AREA mm <sup>2</sup>		1688.002
PERIMETER mm.		1433.021
WEIGHT kg/m		4.558
DRAWING No.		SECTION No.
7594		-
26317		26317

1. ALL DIMENSIONS ARE IN mm.
2. ROUND OFF ALL SHARP CORNERS WITH 0.4mm.
3. TOLERANCES WILL BE AS PER IS:3965-1981 UNLESS OTHERWISE SPECIFIED

PARTY'S NAME	SANDHU ENGINEERS, MOHALI
PARTY'S DRAWING No.	-
ALLOY & TEMPER	HE9 WP
DESCRIPTION	HEAT SINK SECTION