

P-4365

7664

26320

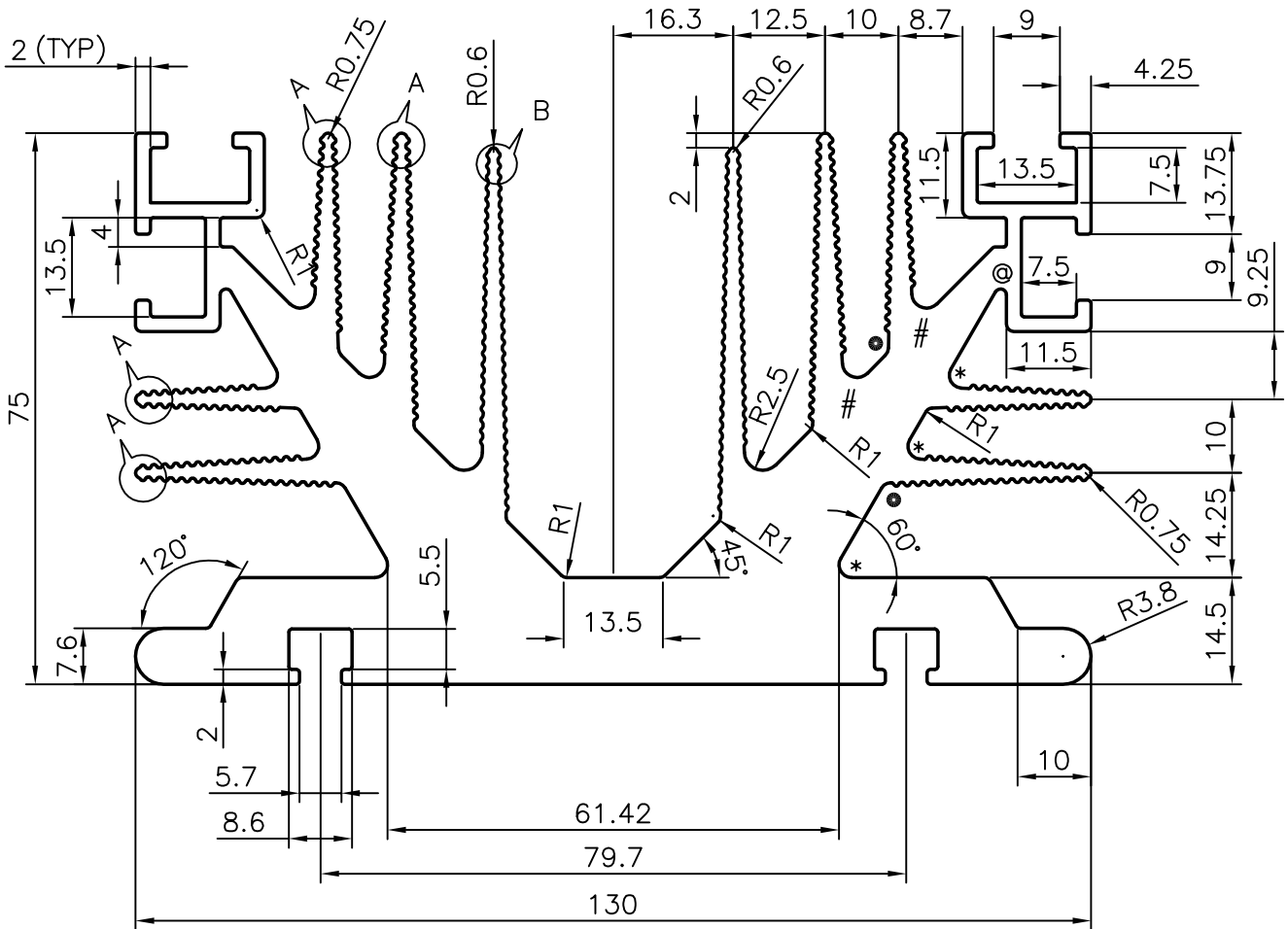
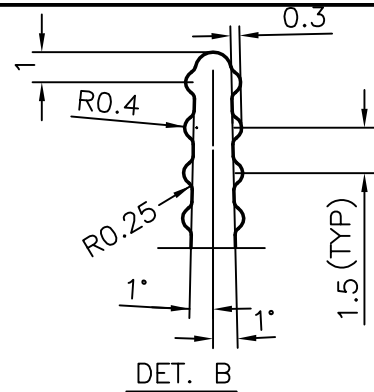
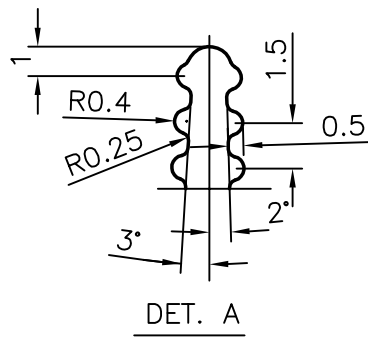

- @ = 0.8R
- = 1.5R
- * = 1.75R
- # = 2R



SYMBOL OF QUALITY
AN ISO 9002 COMPANY

JINDAL ALUMINIUM LTD.
BANGALORE-560073 (INDIA)

	NAME	DATE
DRAWN	PANDAGRE	08.08.2003
CHECKED		
APPROVED		

1. ALL DIMENSIONS ARE IN mm.
2. ROUND OFF ALL SHARP CORNERS WITH 0.40 mm.
3. TOLERANCES WILL BE AS PER IS: 3965-1981 UNLESS OTHERWISE SPECIFIED

SCALE	1:1 , 4:1
AREA mm ²	3980.24
PERIMETER mm.	1487.31
WEIGHT kg/m	10.746

PARTY'S NAME: AAR AAR ENTERPRISES, NEW DELHI

PARTY'S DRAWING No.: AS PER SAMPLE

ALLOY & TEMPER: HE9 WP

DESCRIPTION: HEAT SINK

DRAWING No.	SECTION No.
P-4365	-
7664	7664
26320	26320