

P-3314-1  
S701  
7665  
26321

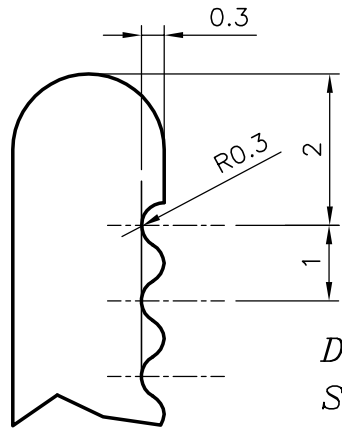

NOTE:-  
1. F=FULL RADII (4-PLCS)

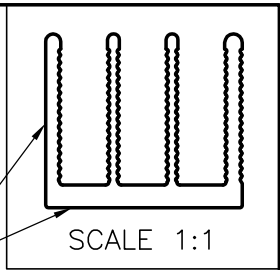

SURFACE SHOULD BE FREE FROM SCRATCHES (FINE FINISH)

DETAIL A  
SCALE 10:1

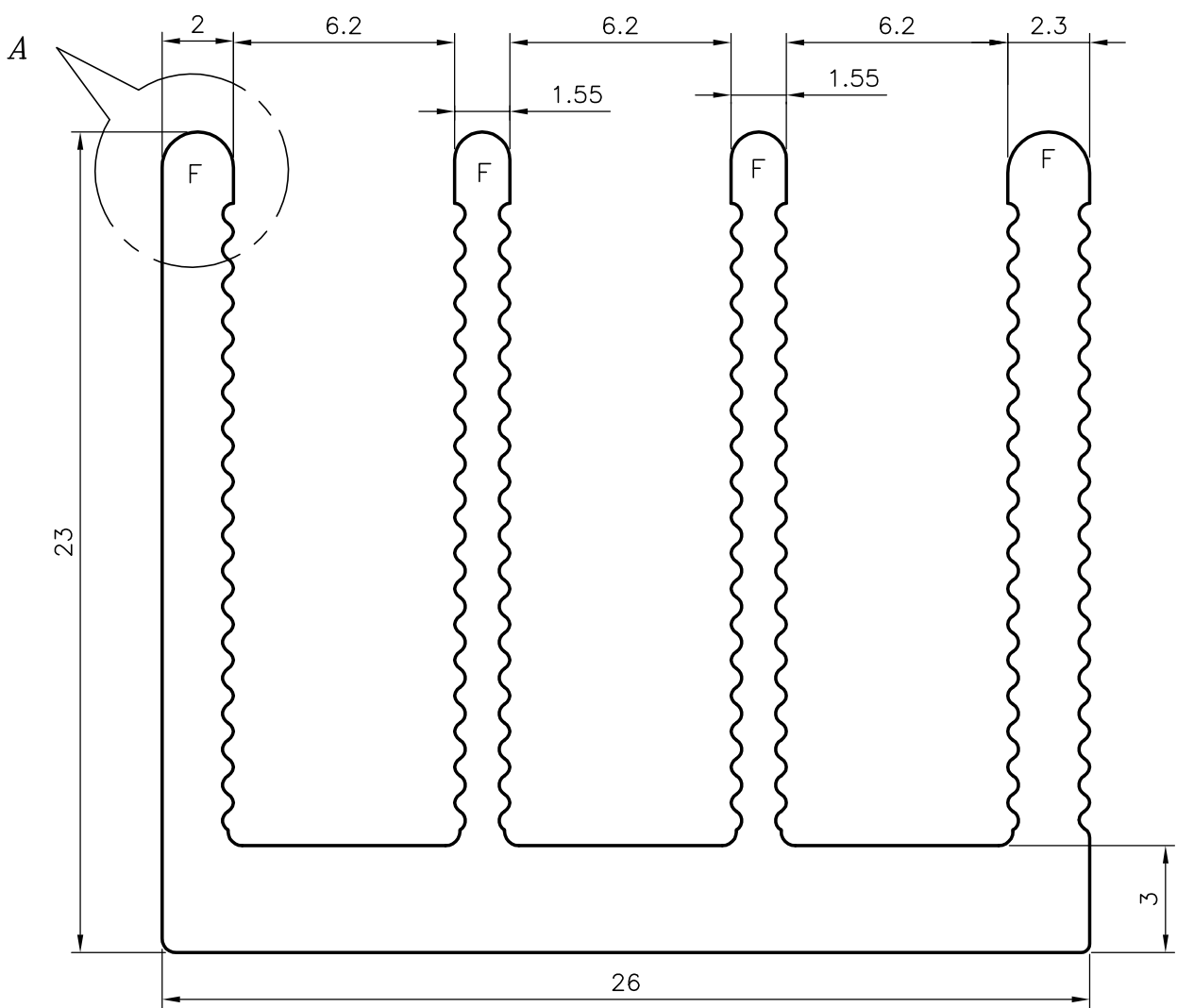

**JINDAL ALUMINIUM LTD.**  
BANGALORE-560073 (INDIA)

	NAME	DATE
DRAWN	RAGHAVENDRA	31-07-01
CHECKED		
APPROVED		

1. ALL DIMENSIONS ARE IN mm.
2. ROUND OFF ALL SHARP CORNERS WITH 0.40 mm.
3. TOLERANCES WILL BE AS PER IS: 3965-1981 UNLESS OTHERWISE SPECIFIED

PARTY'S NAME	TUMKUR PRECISION PRESSING ,TUMKUR
PARTY'S DRAWING No.	AS PER DRAWING
ALLOY & TEMPER	HE9 WP
DESCRIPTION	HEAT SINK

SCALE	1:1 5:1
WEIGHT kg/m	0.552
PERIMETER	242.20mm
SECTION No.	26321
DRAWING No.	26321