

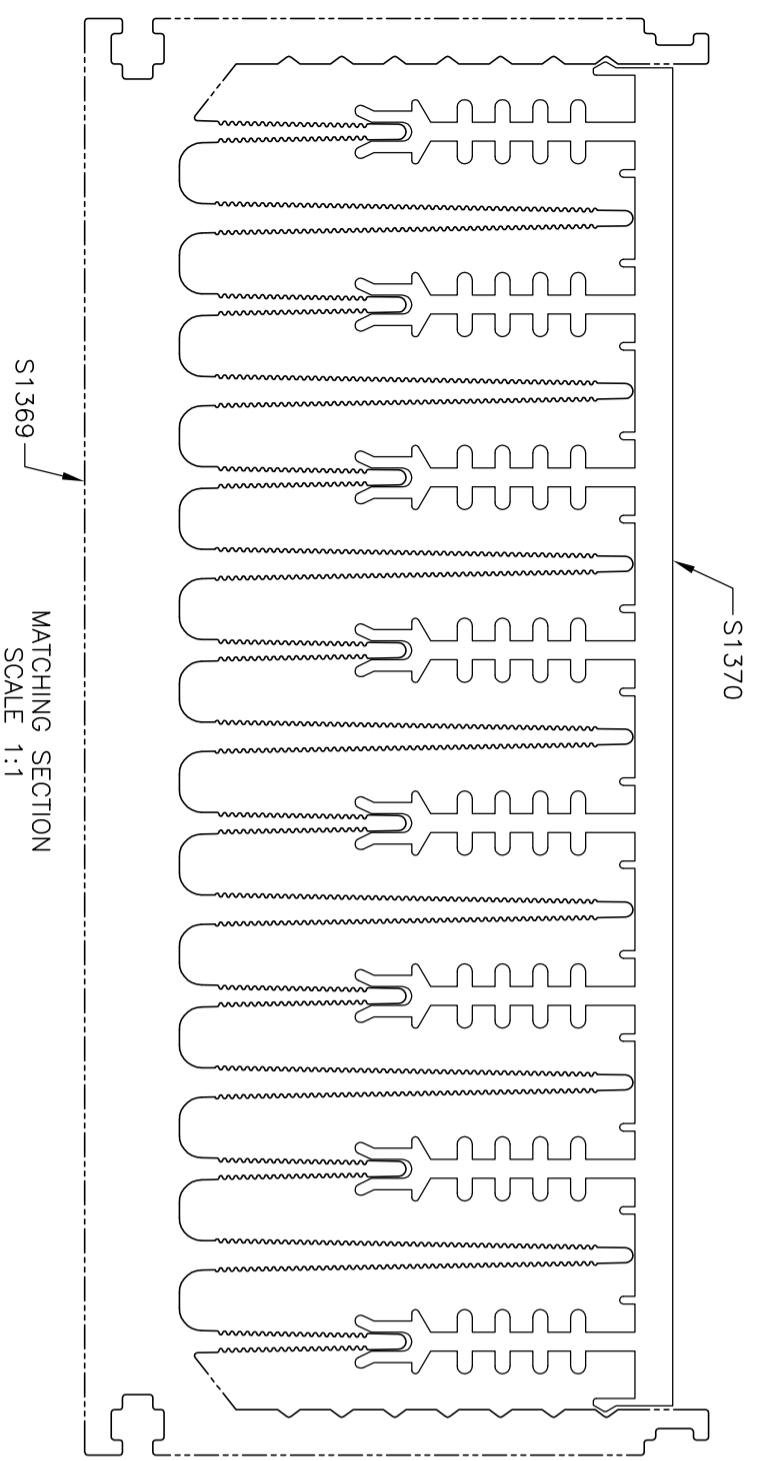

P-5161-1
S1370
26379

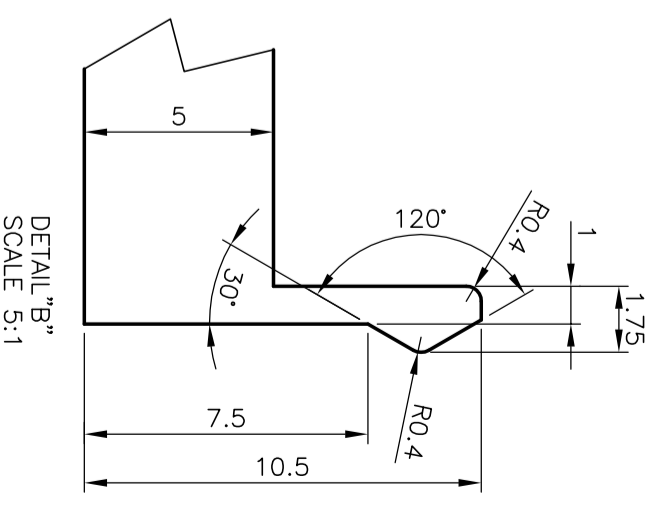
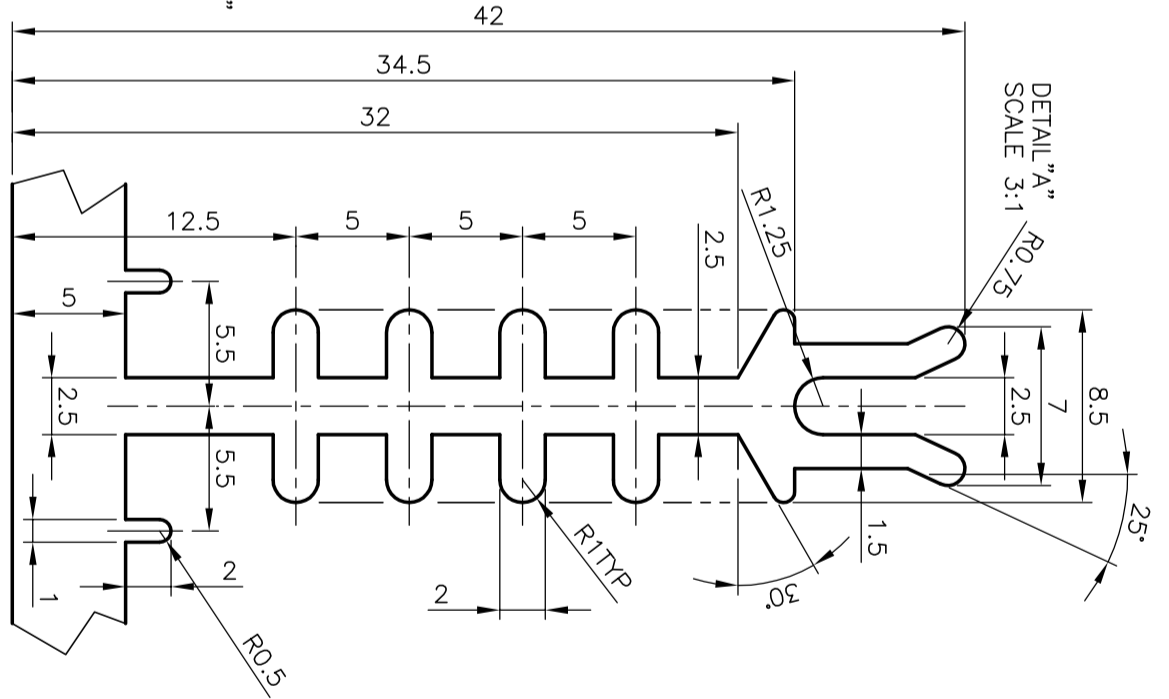
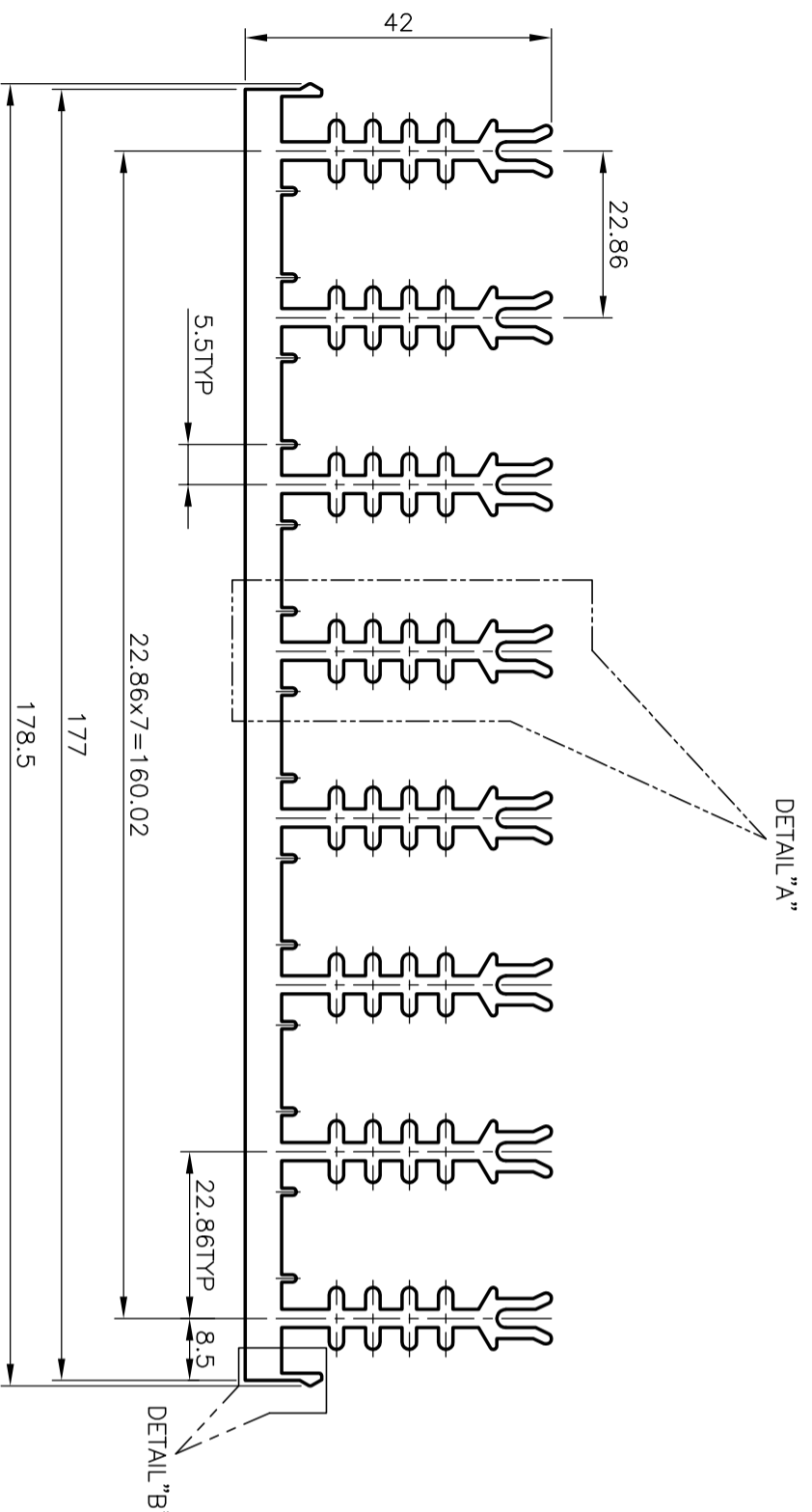

 SYMBOL OF QUALITY AN ISO 9001 COMPANY	JINDAL ALUMINIUM LTD. BANGALORE-560073 (INDIA)	
	1. ALL DIMENSIONS ARE IN mm. 2. ROUND OFF ALL SHARP CORNERS WITH 0.40 mm. 3. TOLERANCES WILL BE AS PER IS:3965-1981 UNLESS OTHERWISE SPECIFIED	
PARTY'S NAME	EMERSON NETWORK POWER (INDIA) PVT LTD, THANE	
PARTY'S DRAWING No.	011200120004	
ALLOY & TEMPER	E1E 'M' (19501)	
DESCRIPTION	HEAT SINK	
DRAWN	NAME	DATE
CHECKED	RAGHAVENDRA	03-12-2004
APPROVED		
SCALE	1:1	
AREA	mm ²	2134.112
PERIMETER	mm.	1535.303
WEIGHT	kg/m	5.762
DRAWING No.	SECTION No.	
P-5161-1	-	
S1370	S1370	
26379	26379	