

DETAIL OF "A"
SCALE 4:1

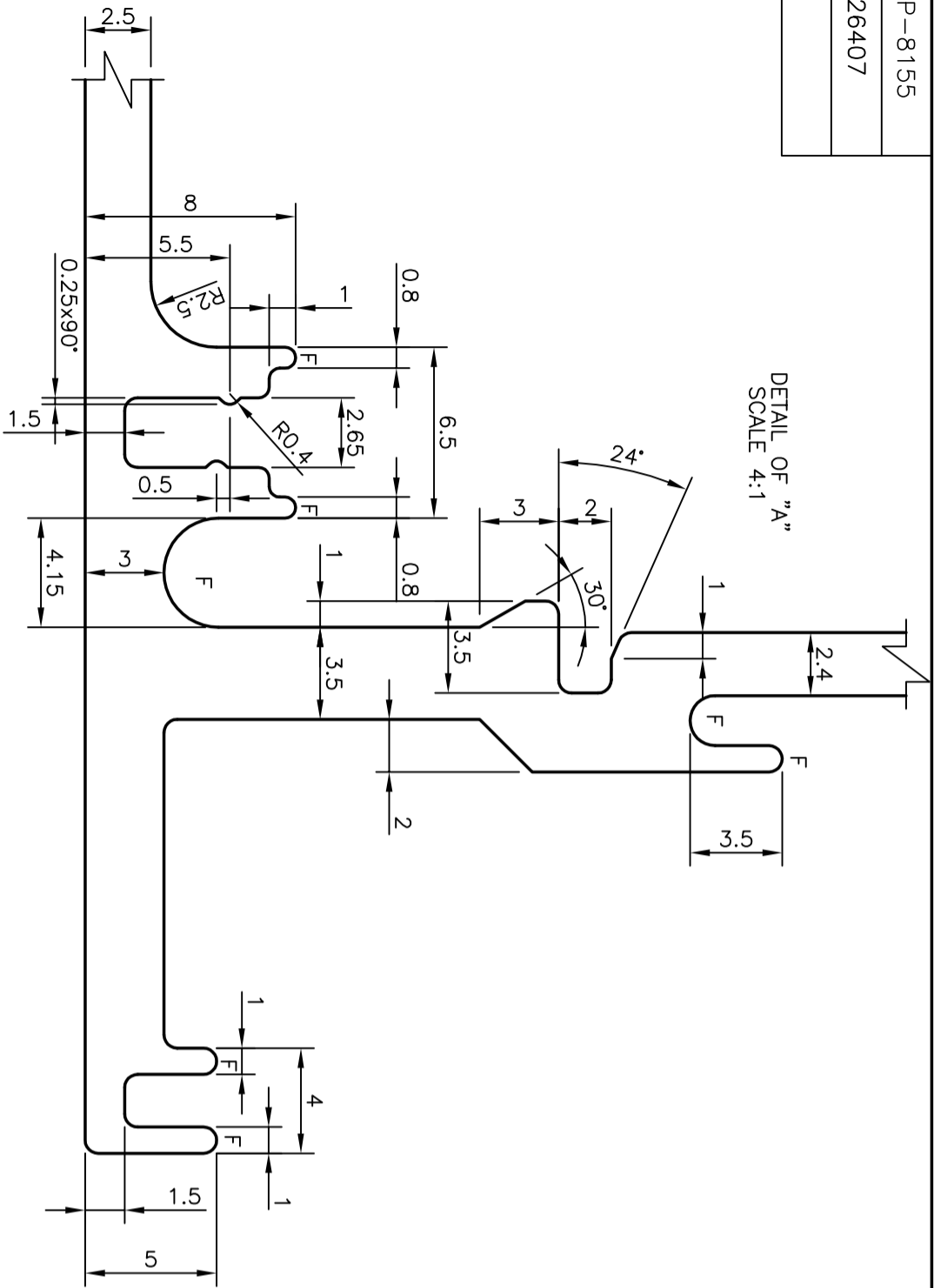

DETAIL OF "C"
SCALE 3:1

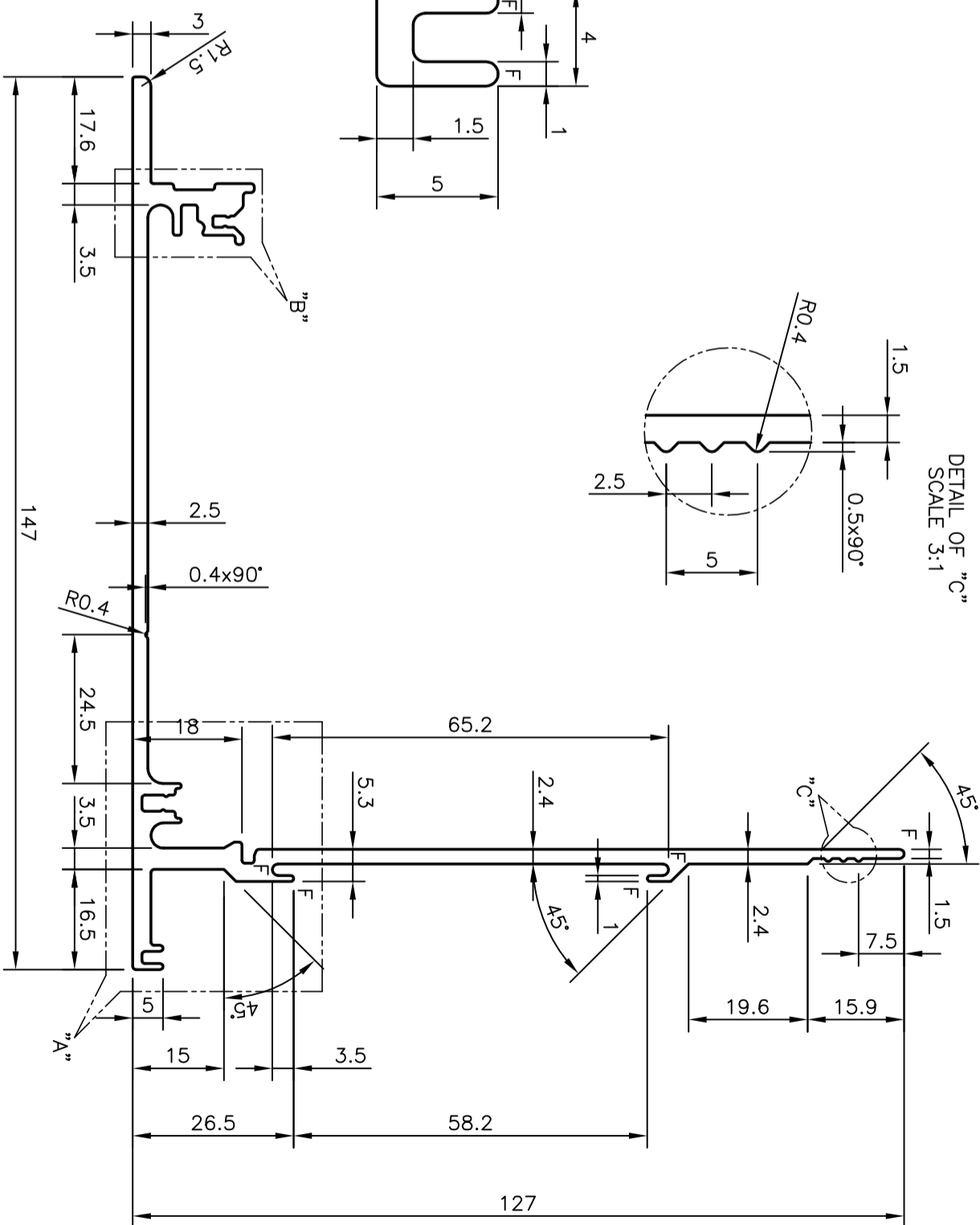
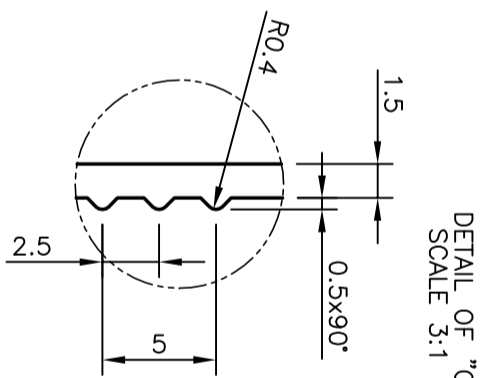

F = FULL RADIUS (11 PLACES)

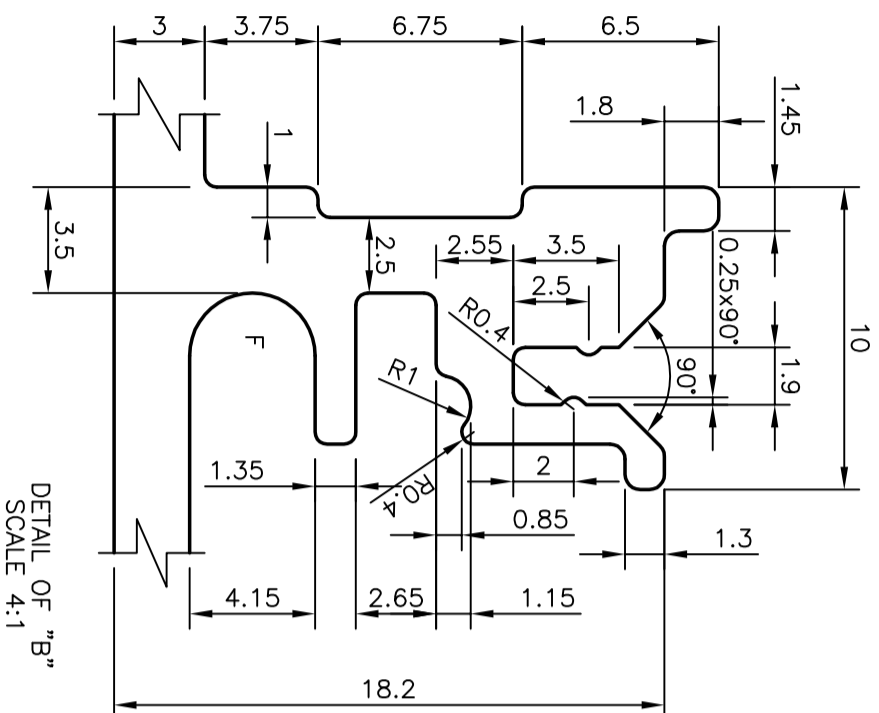

DETAIL OF "B"
SCALE 4:1

 SYMBOL OF QUALITY AN ISO 9001 COMPANY		JINDAL ALUMINIUM LTD. BANGALORE-560073 (INDIA)		NAME	DATE
1. ALL DIMENSIONS ARE IN mm. 2. ROUND OFF ALL SHARP CORNERS WITH 0.40 mm. 3. TOLERANCES WILL BE AS PER IS:3965-1981 UNLESS OTHERWISE SPECIFIED		DRAWN	PRASANNAH	17-04-2008	
PARTY'S NAME	SFO TECHNOLOGIES PVT. LTD., BANGALORE	CHECKED			
PARTY'S DRAWING No.	AS PER SAMPLE	APPROVED			
ALLOY & TEMPER	6063 T6	SCALE	1:1		
DESCRIPTION	HEAT SINK SECTION	AREA mm ²	823.577		
		PERIMETER mm.	661.651		
		WEIGHT kg/m	2.224		
		DRAWING No.	26407		
		SECTION No.	-		