

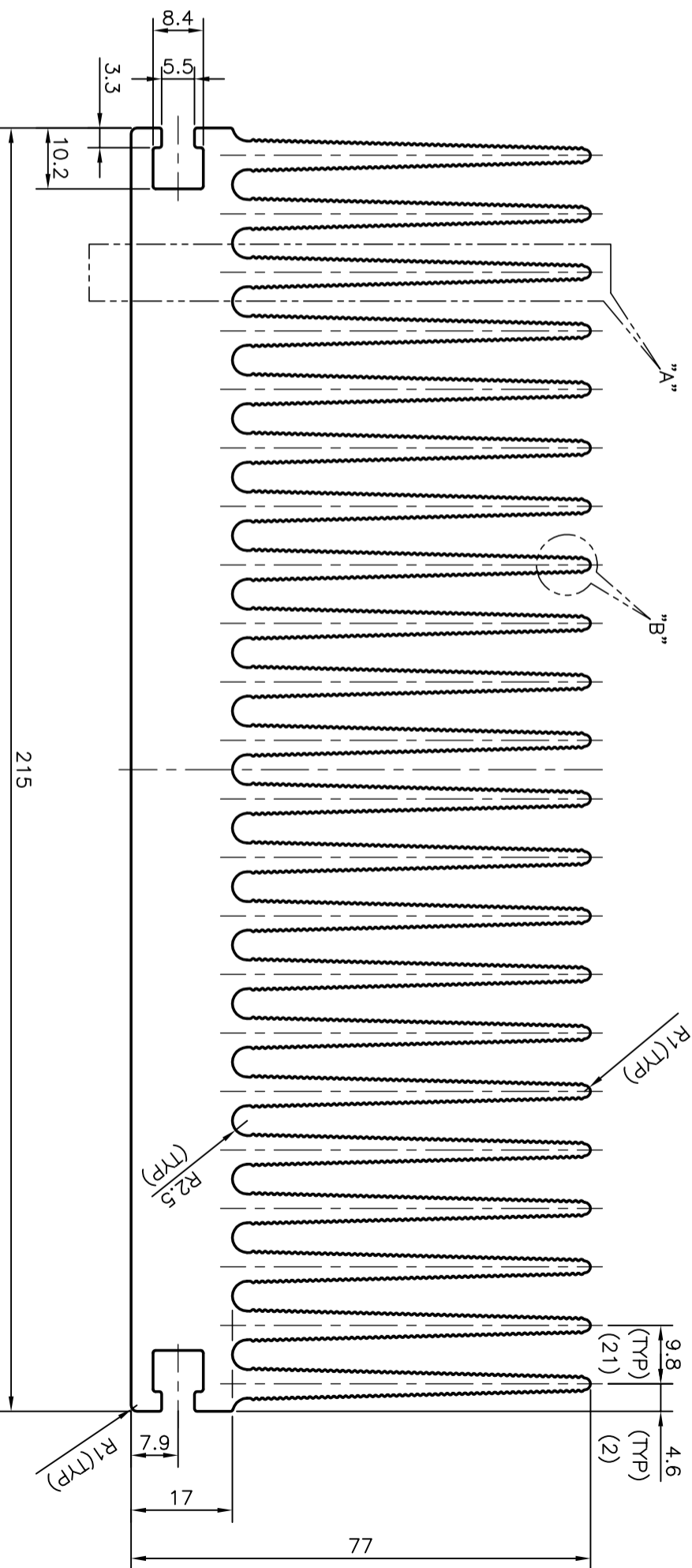

DETAIL OF "B"
SCALE 3:1

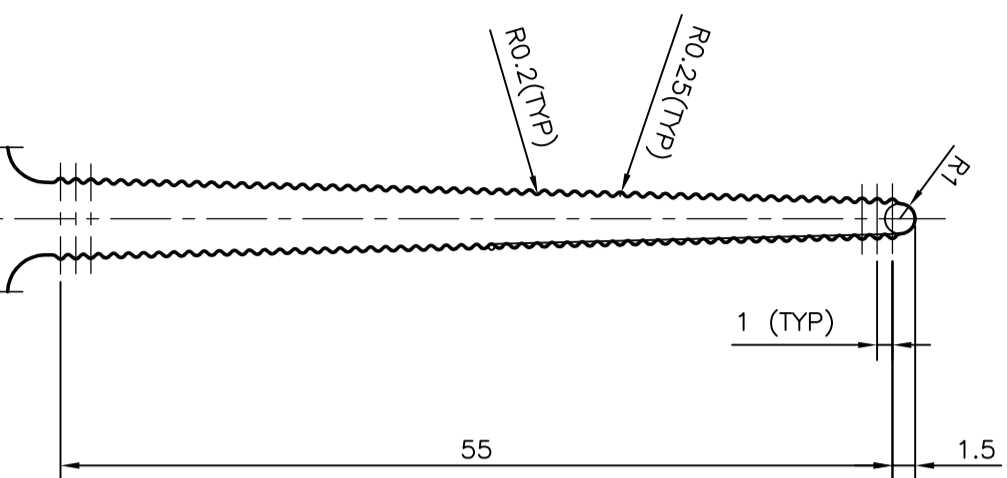
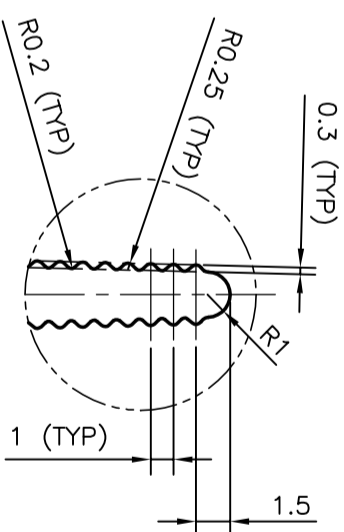

DETAIL OF "A"
SCALE 2:1

 SYMBOL OF QUALITY AN ISO 9001 COMPANY	JINDAL ALUMINIUM LTD. BANGALORE-560073 (INDIA)		DRAWN ABHA	NAME ABHA	DATE 24-06-2008
	1. ALL DIMENSIONS ARE IN mm. 2. ROUND OFF ALL SHARP CORNERS WITH 0.40 mm. 3. TOLERANCES WILL BE AS PER IS:3965-1981 UNLESS OTHERWISE SPECIFIED		CHECKED APPROVED		
PARTY'S NAME SEMIKRON ELECTRONICS PVT. LTD., MUMBAI	PARTY'S DRAWING No. AS PER SAMPLE & CUSTOMER REQUIREMENT	SCALE 1:1	AREA mm ² 8467.585	WEIGHT kg/m 22.862	SECTION No.
ALLOY & TEMPER 6063 T6	DESCRIPTION HEAT SINK SECTION	DRAWING No. P-8392-1 26415	PERIMETER mm. 3524.285	DRAWING No. 26415	SECTION No.